



International Journal for Innovative Engineering and Management Research

A Peer Reviewed Open Access International Journal

www.ijiemr.org

COPY RIGHT

2017 IJIEMR. Personal use of this material is permitted. Permission from IJIEMR must be obtained for all other uses, in any current or future media, including reprinting/republishing this material for advertising or promotional purposes, creating new collective works, for resale or redistribution to servers or lists, or reuse of any copyrighted component of this work in other works. No Reprint should be done to this paper, all copy right is authenticated to Paper Authors

IJIEMR Transactions, online available on 3rd June 2017. Link :

<http://www.ijiemr.org/downloads.php?vol=Volume-6&issue=ISSUE-3>

Title: Design of Encoder And Decoder Using Modified Golay Code

Volume 06, Issue 03, Pages: 635 – 640.

Paper Authors

***NADELLA LAKSMIDEVI, CH L S S PAVAN KUMAR, DURGA PRASAD.B.**

*A.K.R.G College of Engineering & Technology Nallajerla, A.P. India



USE THIS BARCODE TO ACCESS YOUR ONLINE PAPER

To Secure Your Paper As Per **UGC Guidelines** We Are Providing A Electronic Bar Code

Design Of Encoder And Decoder Using Modified Golay Code

NADELLA LAKSMIDEVI¹ CH L S S PAVAN KUMAR² DURGA PRASAD.B.³

¹PG Scholar Dept of E.C.E, A.K.R.G College of Engineering & Technology Nallajerla, A.P. India

²Assistant professor Dept of E.C.E, A.K.R.G College of Engineering & Technology Nallajerla, A.P. India

³H.O. Dept of E.C.E. A.K.R.G College of Engineering & Technology Nallajerla, A.P. India

ABSTRACT: Golay codes are ECC codes and consequently data rate is more. They are linear error correcting codes for transmitting a message over a noisy transmission channel. Golay codes are finding the increase use in applications requiring reliable and highly efficient information transfer over noisy channels. These codes are capable of performing near to Shannon limit performance, Low Decoding Complexity. The main advantage of the parity check matrix is the decoder can correct all single-bit errors. In this Paper Golay encoder and decoder architecture for coding 3-bit message vector will be analyzed and also designed using verilog.

Keywords: Golay, Parity matrix, Generator matrix, Shannon's Coding Theorem

1. INTRODUCTION

Golay codes have recently attracted tremendous research interest because of their excellent error-correcting performance and highly parallel decoding scheme. Golay codes have been selected by the digital video broadcasting (DVB) standard and are being seriously considered in various real-life applications such as magnetic storage, 10 GB Ethernet, and high-throughput wireless local area network. They are class of linear block. Claude Shannon, generally regarded as the father of the Information Age, published the paper: "A Mathematical Theory of Communications" which laid the foundations of Information Theory.

Every communication channel is characterized by a single number C , called the channel capacity. It is possible to transmit information over this channel reliably (with probability of error $\rightarrow 0$) if and only if:

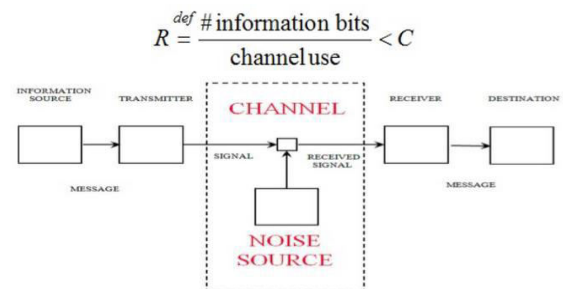

Figure 1. Noise Communication System

Shannon introduced the concept of codes as ensembles of vectors that are to be transmitted. To achieve reliable communication, it is thus imperative to send input elements that are correlated. This leads to the concept of a code, defined as a (finite) set of vectors over the input alphabet. The code has a rate of k/n bits per channel use, or k/n bpc ($k=\log_2 M$).

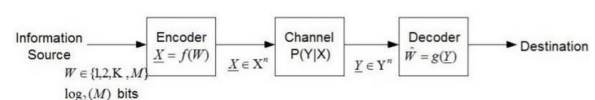

Figure 2. Message Passing between Sources to Destination

The code rate is given by:

$$R = \frac{\log_2(M)}{n} \quad \frac{\text{bits}}{\text{channel use}}$$

Reliable transmission is possible if $R < C$. codes, as their name suggests low density means number of 1's in the parity matrix is very small compare to 0's. Condition for low density is $W_c \ll m$ and $W_r \ll n$, where W_c represents the column weight and W_r represents the row weight. The sparseness of parity matrix guarantees that the complexity of decoding algorithm increases only with increasing code length. In this coding technique we are going to use two matrixes one is generator matrix G at encoder and parity check matrix 'H' at decoder. Rows of the parity matrix represent the check nodes and columns represent the variable nodes of the Tanner graph. Bits in the codeword are based on the variable nodes and bits in the message vector are based on the check nodes. They are two types of parity check matrix, one is regular in which column weights and row weights are same for all columns and rows respectively and other one is Irregular in which column and row weights are different for each columns and rows respectively.

2. System Design

Here we have divided our entire Golay system in to three major blocks mainly,

- 1) Encoder block
- 2) Noise insertion block (AWGN - channel)
- 3) Decoder block

2.1. Golay Algorithm

A codeword c is generated as $C = KP$ (1) where K is the message vector and G is the generator matrix. A valid codeword can be verified using $CHT = 0$ (2). Where H is the

parity check matrix. If the result in (2) is nonzero, the codeword C is invalid and an error correction procedure should be used in this case. The Bit flipping method uses a vector, called syndrome, which is computed as $S = YHT$, (3). Where Y is the invalid codeword. The syndrome indicates which row in the H is not zeroed by vector Y and some bits have to be repaired in the decoder. If the parity check matrix has low size, we can find an error floor of the Golay code, where one erroneous bit is repaired and BER is close to zero or is zero.

2.2. Design of Golay Architecture using VHDL Coding

Where "Y" is the invalid Code Word. The syndrome indicates which row in the H is not zeroed by vector Y and some bits have to be repaired in the decoder. If the parity check matrix has low size, we can find an error floor of the Golay code, where one erroneous bit is repaired and BER is close to zero or is zero.

3. Encoder Design

Encoder uses generator matrix to encode the information bits in to the code word. Both generator and parity check matrix are interrelated, parity check matrix is given by

$$H = [PT | I] \text{ (or) } H = [In-P | I]$$

and the generator matrix is given by

$$G = [I | PT]$$

Initially parity check matrix is generated, using that matrix generator matrix is created by Gaussian elimination method. There are two types of parity matrices in LDPC coding one is Regular matrix and another one is irregular matrix. Regular matrix is one in which column W_c is same for all columns and row weight is given by

$$W_r = W_c(n/m)$$

In this paper we are using regular matrix of 3×7 (or) $(n,k)=(7,3)$ i.e., where n represents total bits and k represents message bits, $n-k=7-3=4$ which represents check bits or parity bits.

$$\begin{pmatrix} 1011001 \\ 1110100 \\ 1100010 \\ 0110001 \end{pmatrix}$$

Figure 3. Regular Parity Matrix

To transfer the above parity check matrix to standard form i.e $H=[PT | I]$ Gaussian elimination method is applied to the above matrix. The matrix H is put into this form by applying elementary row operations which are interchanging two rows or adding one row to another modulo 2. The resulting parity matrix in its standard form H is as shown in the figure 4.

$$\begin{pmatrix} 1011000 \\ 1110100 \\ 1100010 \\ 0110001 \end{pmatrix}$$

Figure 4. Standard Parity Matrix

If G is the generated matrix for (n, k) code then H is the generator matrix for $(n, n-k)$ code. Therefore obtained parity matrix is translated to standard form generator matrix i.e., $G=[I | P]$ as shown in fig 5,

$$\begin{pmatrix} 0001110 \\ 0100111 \\ 0011101 \end{pmatrix}$$

Figure 5. Generator Matrix

3. Proposed System

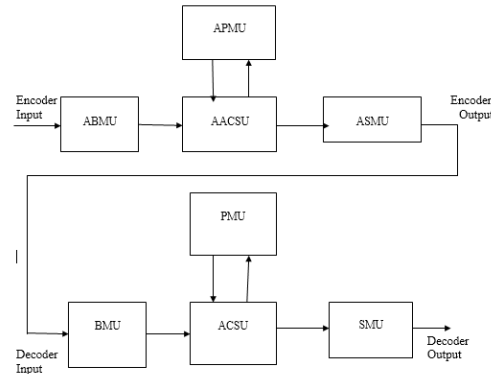

Figure 6 Block Diagram Of Modified Golay

Modified Golay consists of both encoder and decoder. Encoder converts the digital signal in to the analog signal. Decoder converts the analog signal into digital signal.

Encoder usually consists of the following major blocks:

- 3.1. Branch Metric Unit (ABMU)
- 3.2. Path Metric Unit (APMU)
- 3.3. Add-Compare-Select Unit (AACSU)
- 3.4. Survivor Management Unit (ASMU)

Encoder output is given as input to the decoder of the modified Golay. A modified Golay uses the Golay algorithm for decoding a bitstream that has been encoded using convolution code or trellis code. A hardware Golay decoder for basic code usually consists of the following major blocks:

- 3.1. Branch Metric Unit (BMU)
- 3.2. Path Metric Unit (PMU)
- 3.3. Add-Compare-Select Unit (ACSU)
- 3.4. Survivor Management Unit (SMU)

3.1. Branch metric unit (BMU)

A branch Metric Unit's function is to calculate branch metrics, which are normed distances between every possible symbol in the code alphabet, and the received symbol. There are hard decision and soft decision Golay decoders. A hard decision Golay decoder receives a simple bit stream on its input, and a Hamming distance is used as a metric. A soft decision Golay decoder receives a bit stream containing information about the reliability of each received symbol.

3.2. Path metric unit (PMU)

A path Metric Unit summarizes branch metrics to get metrics for paths, where K is the constraint length of the code, one of which can eventually be chosen as optimal. Every clock it makes decisions, throwing off wittingly non optimal paths. The core elements of a PMU are ACS (Add-Compare-Select) units. The way in which they are connected between themselves is defined by a specific code's trellis diagram.

3.3. Add-Compare-Select Unit(ACSU)

The add-compare-select unit(ACSU) which selects the survivor paths for each trellis state, also finds the minimum path metric of the survivor paths.

3.4. Survivor Management Unit (SMU)

The survivor management unit (SMU) that is responsible for selecting the output based on the minimum path metric.

Golay algorithm is called optimum algorithm since it minimizes the probability of error.

4. Result

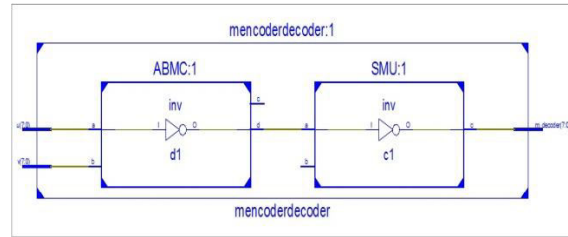

Figure 7: RTL Schematic Diagram

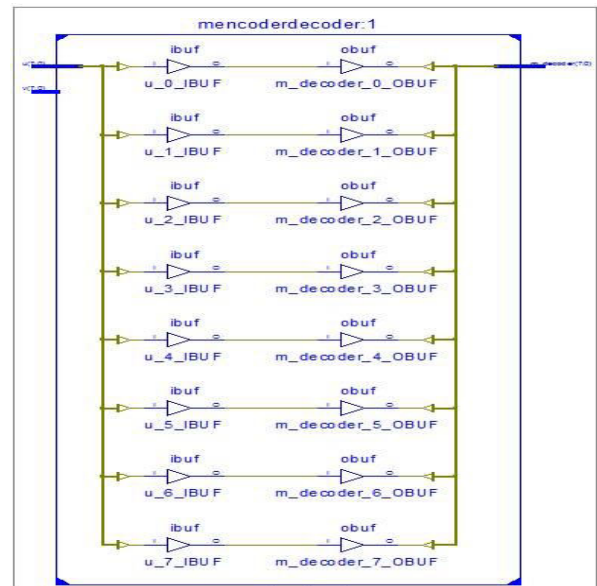

Figure 8: Technologic Schematic

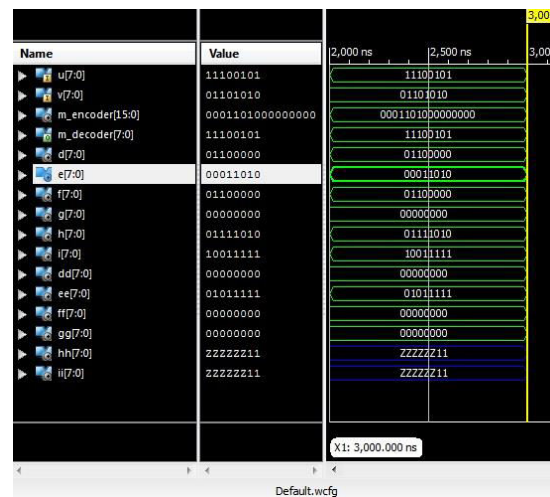

Figure 9: Output Waveform

5. Conclusion

Golay coding is a superior error correcting coding technique which allows further error modification and hence data rate of transmission is elevated. In this paper Design of Encoder, channel and Decoder is for a Golay codes is presented. Coding is done using (7, 3) Golay code. Coding is done on HDL Designer Series and simulation results are obtained from Xilinx 14.7.

5.2. Applications of Golay

Golay codes have already been adopted in satellite-based digital video broadcasting and long-haul optical communication standards, are highly likely to be adopted in the IEEE wireless local area network standard, and are under consideration for the long-term evolution of third generation mobile telephony. Golay is also used for 10GBase-T Ethernet, which sends data at 10 gigabits per second over twisted-pair cables. Golay codes are also part of the Wi-Fi 802.11 standard as an optional part of 802.11n and 802.11ac, in the High Throughput (HT) PHY specification.

6. References

- [1] Satyabrata Sarangi and Swapna Banerjee, "Efficient Hardware Implementation of Encoder and Decoder for Golay Code", IEEE Transactions On Very Large Scale Integration (VLSI) Systems 2014.
- [2] Xiao-Hong Peng, Member, IEEE, and Paddy G. Farrell, Life Fellow, IEEE, "On Construction of the (24, 12, 8) Golay Codes", IEEE Manuscript received January 19, 2005; revised July 7, 2005 and December 15, 2005, respectively.
- [3] W. Cao, "High-speed parallel hard and soft-decision Golay decoder: Algorithm and VLSI-architecture," in Proc. IEEE Int. Conf. Acoust., Speech, Signal Process. (ICASSP), vol. 6. May 1996, pp. 3295–3297.
- [4] Ayyoob D. Abbaszadeh and Craig K. Rushforth, Senior Member, IEEE, "VLSI Implementation of a Maximum Likelihood Decoder for the Golay (24, 12) Code", IEEE Journal on Selected Areas in Communications. VOL. 6, NO. 3, APRIL 1988.
- [5] W. Cao, "High-speed parallel VLSI-architecture for the (24, 12) Golay decoder with optimized permutation decoding," in Proc. IEEE Int. Symp. Circuits Syst. (ISCAS), Connecting World, vol. 4. May 1996, pp. 61–64.
- [6] P. Adde, D. G. Toro, and C. Jago, "Design of an efficient maximum likelihood soft decoder for systematic short block codes," IEEE Trans. Signal Process. vol. 60, no. 7, pp. 3914–3919, Jul. 2012.
- [7] B. Honary and G. Markarian, "New simple encoder and trellis decoder for Golay Codes", ELECTRONICS LETTERS 9th December 1993 Vol. 29 No. 25.
- [8] Michael Sprachmann, "Automatic Generation of Parallel CRC Circuits", 0740-7475/01/\$10.00 © 2001 IEEE.
- [9] Giuseppe Campobello, Giuseppe Patane, and Marco Russo, "Parallel CRC Realization", IEEE TRANSACTIONS ON COMPUTERS, VOL. 52, NO. 10, OCTOBER 2003.
- [10] G. Solomon, "Golay encoding/decoding via BCH-hamming," Comput. Math. Appl., vol. 39, no. 11, pp. 103–108, Jun. 2000.
- [11] I. Boyarinov, I. Martin, and B. Honary, "High-speed decoding of extended Golay Code," IEE Proc. Commun., vol. 147, no. 6, pp. 333–336, Dec. 2000.
- [12] D. C.



Hankersonet al., Coding Theory and Cryptography The Essentials, 2nd ed. New York, NY, USA: Marcel Dekker, 2000.

[13] M.-H. Jing, Y.-C. Su, J.-H. Chen, Z.-H. Chen, and Y. Chang, "High-speed low-complexity Golay decoder based on syndromeweight determination," in Proc. 7th Int. Conf. Inf., Commun., SignalProcess. (ICICS), Dec. 2009, pp. 1–4.

[14] T.-C. Lin, H.-C. Chang, H.-P. Lee, and T.-K. Truong, "On the decoding of the (24, 12, 8) Golay Code," Inf. Sci., vol. 180, no. 23, pp. 4729–4736, Dec. 2010.