

International Journal for Innovative Engineering and Management Research

A Peer Reviewed Open Access International Journal

www.ijiemr.org

COPY RIGHT

2018 IJIEMR. Personal use of this material is permitted. Permission from IJIEMR must be obtained for all other uses, in any current or future media, including reprinting/republishing this material for advertising or promotional purposes, creating new collective works, for resale or redistribution to servers or lists, or reuse of any copyrighted component of this work in other works. No Reprint should be done to this paper, all copy right is authenticated to Paper Authors IJIEMR Transactions, online available on 23rd April 2018. Link :

<http://www.ijiemr.org/downloads.php?vol=Volume-6&issue=ISSUE-3>

Title: A Simulink Approach With PWM Control Technique for Integrated Inverter/Converter Circuit and Control Technique of Motor Drives With Dual Mode Control for EV/HEV Applications

Volume 07, Issue 04, Pages: 141 – 150.

Paper Authors

MOOLI KAVITHA, DOROTHY HRACE KOTA

Dept of EEE, Universal Engineering College, Perecharla , Guntur(Dt) AP, India.



USE THIS BARCODE TO ACCESS YOUR ONLINE PAPER

To Secure Your Paper As Per **UGC Guidelines** We Are Providing A Electronic Bar Code



A SIMULINK APPROACH WITH PWM CONTROL TECHNIQUE FOR INTEGRATED INVERTER/CONVERTER CIRCUIT AND CONTROL TECHNIQUE OF MOTOR DRIVES WITH DUAL MODE CONTROL FOR EV/HEV APPLICATIONS

MOOLI KAVITHA¹, DOROTHY GRACE KOTA²

MOOLI KAVITHA M-tech Student management Department of Electrical & Electronics Engineering, Universal Engineering College, Perecharla; Guntur (Dt); Andhra Pradesh, India.

DOROTHY GRACE KOTA Assistant Professor Department of Electrical & Electronics Engineering, Universal Engineering College, Perecharla; Guntur (Dt); Andhra Pradesh, India.

ABSTRACT: Hybrid electric vehicles (HEVs) powered by electric machines and an internal combustion engine (ICE) are a promising mean of reducing emissions and fuel consumption without compromising vehicle functionality and driving performances. The proposed integrated circuit allows the permanent magnet synchronous motor to operate in motor mode or acts as boost inductors of the boost converter, and thereby boosting the output torque coupled to the same transmission system or dc-link voltage of the inverter connected to the output of the integrated circuit. Electric Motors, those are used for EV propulsion must have high efficiency for maximum utilization of the energy from batteries and/or fuel cells. Motor control algorithm for a dual power split system is proposed for hybrid electric vehicles (HEV). A new control technique for the proposed integrated circuit under boost converter mode is proposed to increase the efficiency. Since the light load performance is in recent focus of interest, appropriate algorithms to improve light load efficiency were implemented. The proposed control technique is to use interleaved control to significantly reduce the current ripple and thereby reducing the losses and thermal stress under heavy-load condition. In order to evaluate performance of the control algorithm, HEV simulator is developed using MATLAB/ Simulink.

Finally converter model fed induction motor and check the speed torque characteristic of Induction Motor is presented.

INTRODUCTION

Recently, developments in power electronics and semiconductor technology have lead improvements in power electronic systems. Pulse Width Modulation variable speed drives are increasingly applied in many new industrial applications that require superior performance. Hence, different circuit configurations namely multilevel inverters have become popular and considerable interest by researcher are given on them. Variable voltage and frequency supply to A.C drives is invariably obtained from a three-phase voltage source inverter. Hybrid Electric Vehicle (HEV) is an emerging technology in the modern world because of the fact that it mitigates environmental pollutions and at the same time increases fuel efficiency of the vehicles. In vehicular applications, power electronic dc/dc converters require high power bidirectional flow capability with wide input range since the terminal voltage of energy storage devices varies with the state of charge and load variations. Power electronic inverters are widely used in various industrial drive applications. To overcome the problems of the limited voltage and current ratings of

power semiconductor devices, some kinds of series and/or parallel connections are necessary and have several merits such as energy consumption, better system efficiency, improved quality of product, good maintenance, and so on. Many commercial hybrid electric vehicle (HEV) systems use a traditional bidirectional dc-dc converter to interface the battery and the inverter dc bus.

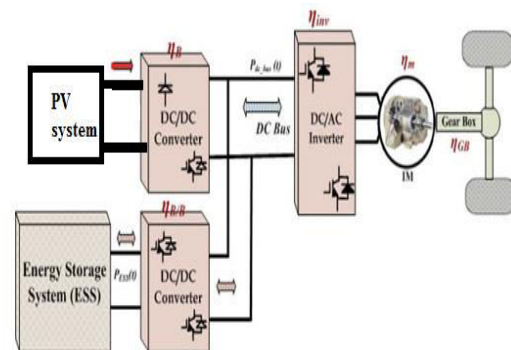

Fig.1 Block diagram of HEV.

There is growing interest in electric vehicle (EV) and hybrid electric vehicle (HEV) technologies because of their reduced fuel usage and greenhouse emissions [1]–[3]. PHEVs have the advantage of a long driving range since fuel provides a secondary resource. Connection to the electric power grid allows opportunities such as ancillary services, reactive power support, tracking the output of renewable energy sources, and

load balance. For purposes of this paper, plug-in vehicles will be lumped together with EVs. Most EV charging can take place at home over night in a garage where the EV can be plugged in to a convenience outlet for Level 1 (slow) charging. Level 2 charging is typically described as the primary method for both private and public facilities and requires a 240 V outlet.

An electric vehicle is an emission free, environmental friendly vehicle. However, the electric vehicles remain unpopular among the consumers due to their lack of performance and their inability to travel long distances without being recharged. So, vehicle that embraces both the performance characteristics of the conventional automobile and the zero-emission characteristics of the electric vehicles are greatly being anticipated by the general consumers and the environmentalists alike. Technically, the quest for higher fuel economy is shaped by two major factors: how efficiently a power train converts fuel energy into useful power, and how sleek a vehicle is in terms of mass, streamlining, tire resistance, and auxiliary loads. On the other hand, vehicle functionality and comfort are shaped by various other factors, many of which run counter to higher fuel economy.

Examples abound, from the way torque converter sacrifices efficiency to provide better shift smoothness and responsiveness to the wide variety of features that add mass to a vehicle.

II. HEV CONFIGURATIONS

A brief description about various HEV configurations available in the market is presented. The three main configurations are the series, parallel and the dual-mode configurations and the explanation of each one of them with their merits and demerits follows.

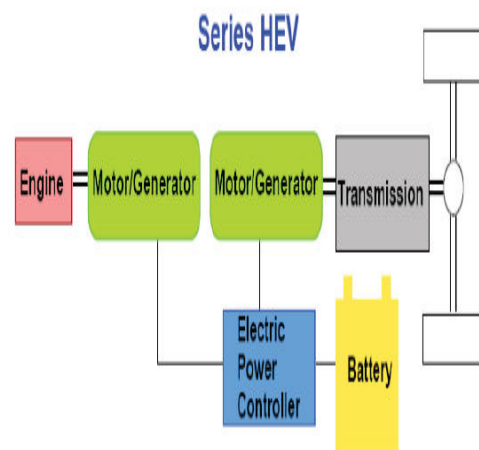

Fig.2 Series HEV drive train.

In series HEV configuration, only the electric motor is connected to the drive train and thus the vehicle is entirely driven by the electric motor. The Internal Combustion (IC) engine drives an electric generator (commonly known as alternator), which then supplies the electric power to the motor and battery pack. The IC engine will turn off if

the battery is fully charged. In some cases, the electric power supply for the electric motor can come both from the battery and the engine generator set. As only the electric motor is

connected to the drive train, the IC engine can run at an optimum speed to run the generator thus greatly reducing the emissions. The batteries can either be charged off-board, by external DC power link from the electric-grid, or on-board, with the help of an alternator and an IC engine. In this setup, it is possible to design the operation such that the IC engine never idles and thus the overall emissions are reduced. The schematics of series HEV is shown in Figure 2.

It can be seen that the IC engine is connected to the alternator (generator) which in turn is connected to the battery pack and electric motor through an electronic control unit. This scheme allows the electric motor to get its power from either battery pack or the alternator or both as per the battery state of charge and vehicle acceleration requirements [4-6].

B. Parallel HEV Configuration

In the parallel HEV configuration there are two power paths for the drive train, while one comes from the engine the other comes

from the electric motor. During short trips the electric motor can power the vehicle, while during long drives the IC engine can power the vehicle. The vehicle can thus have engine only, motor only, or a combination of engine and motor mode of operation. The electric motor can also assist the engine during hill climbs and vehicle accelerations, thus the rating of the IC engine can be reduced. This configuration is illustrated in Figure 3.

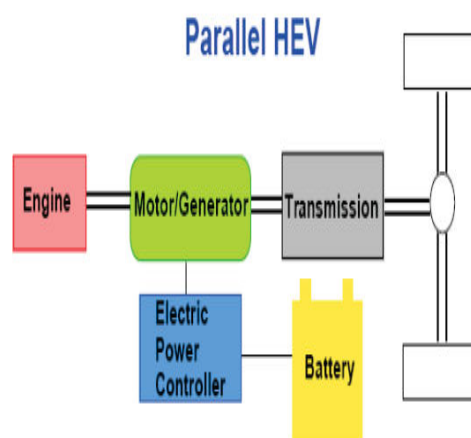

Fig.3 Parallel HEV drive train.

In parallel HEV configuration, the drive train is connected to the electric motor and engine through a mechanical coupling or an angle gear. These vehicles do not require a generator (as in the case of series HEV configuration) and they can be connected to an electric grid (off-board) for recharging the batteries. The electric motor can be made to act as generator via a mechanical clutch which can then be used for

regenerative braking. Both the gas-powered engine and the electric motor can turn the transmission simultaneously, and the transmission, of course, turns the wheels. The fuel tank and gas engine and the batteries and electric motor connect independently to the transmission—as a result, in a parallel hybrid; both the electric motor and the gas engine can provide power.

III. PROPOSED INTEGRATED IRCUIT AND CONTROL TECHNIQUE

A. Proposed Integrated nverter/Converter Circuit

In Fig. 4, C_{in} and C_{out} can stabilize the voltage when input and output voltages are disturbed by source and load, respectively. Diode (D) is used for preventing output voltage impact on the input side. When the integrated circuit is operated in inverter (motor) mode, relay will be turned ON and six power devices are controlled by pulse width modulation (PWM) control signals

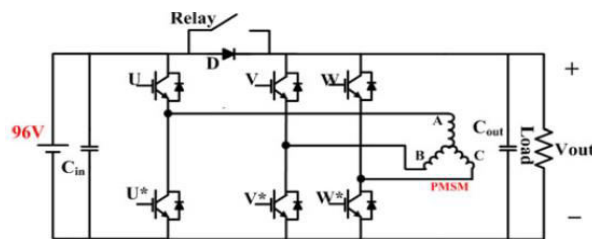

Fig. 4 shows the integrated circuit for dual-mode control.

When the proposed integrated circuit is operated in the converter mode, relay is turned OFF. And a single-phase or interleaved control method will be applied to control of the power devices depending upon the load conditions.

B. Modeling and Controller Design under Boost Mode

This section will introduce the model of boost converter and derive the transfer function of the voltage controller. Fig.5 shows the non ideal equivalent circuit of the boost converter, it considers non ideal condition of components: inductor winding resistance R_L , collector-emitter saturation voltage V_{CE} , diode forward voltage drop V_D , and equivalent series resistance of capacitor R_{esr} .

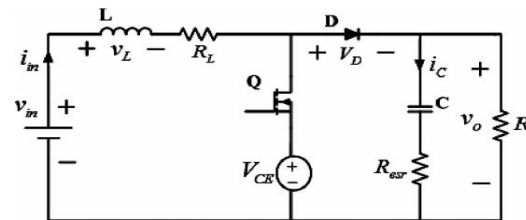

Fig.5 Equivalent circuit of the boost converter

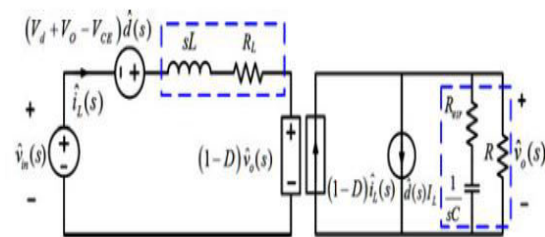

Fig.6. Small-signal equivalent circuit.

Analysis of the boost converter by using the state-space averaging method [4], small-signal ac equivalent circuit can be derived, as shown in Fig. 6.

$$G_{vd}(s) = \frac{-6.737 \times 10^{-5} s^2 + 0.06827s + 2498}{2.004 \times 10^{-5} s^2 + 0.00409s + 3.242} \quad (1)$$

Fig. 7 shows the block diagram of voltage loop, using a proportional-integral (PI) controller for the compensator. In this paper, the switching frequency is 20 kHz and voltage loop bandwidth will be less than 2 kHz. And the phase margin should be more than 45° to enhance the noise immunity. For the designed controller shown in (2), proposed converter interfaced to induction machine through inverter topology.

$$C(s) = \frac{0.0248387s + 13.073}{s} \quad (2)$$

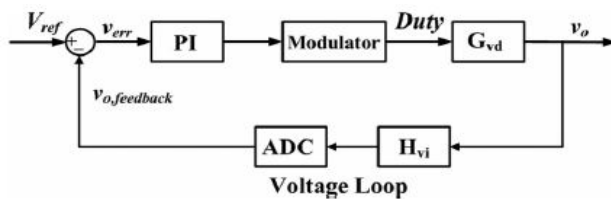

Fig.7 Block diagram of voltage loop.

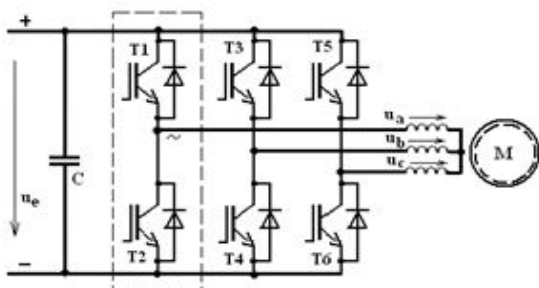

Fig.8 Proposed Converter Applied to Induction Machine Drive System.

IV. SIMULATION RESULTS

Here the simulation carried by two different cases they are 1) Proposed interleaved boost converter multiplier module. 2) Proposed converter with interleaved boost converter Applied to Induction Machine Drive.

Case-1. Proposed interleaved boost converter

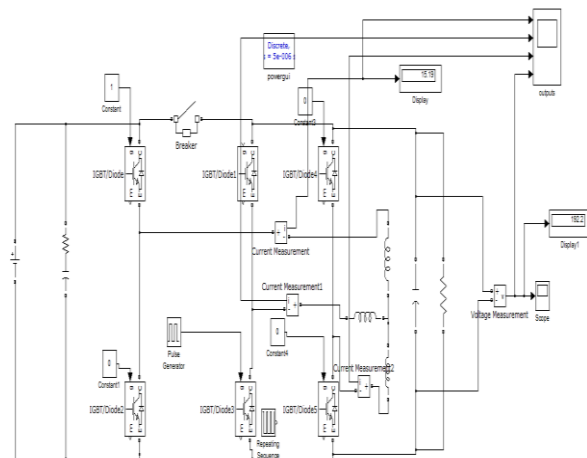

Fig.9 Matlab/simulink model of the integrated circuit and controller.

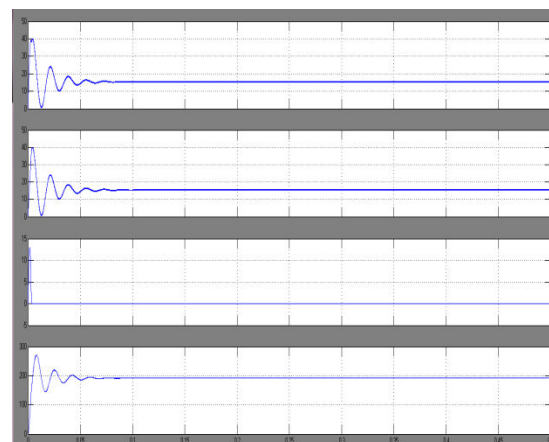

Fig.10 measured current with and without interleaved control, Single-phase interleaved boost converter

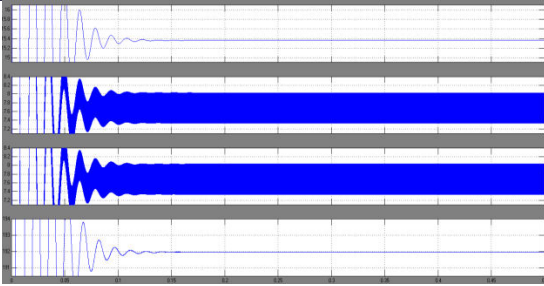

Fig.11. Measured current with and without interleaved control, Two-phase interleaved boost converter.

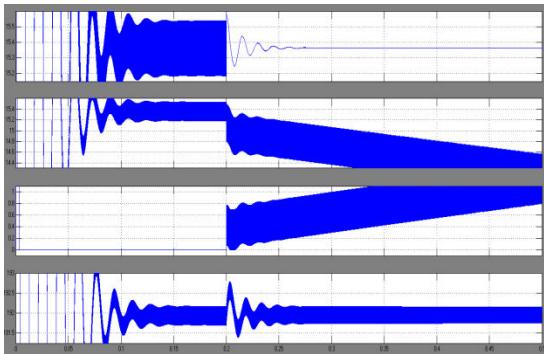

Fig. 12.simulated waveforms for the transition between single-phase control and two-phase interleaved control from two-phase interleaved to single-phase modes.

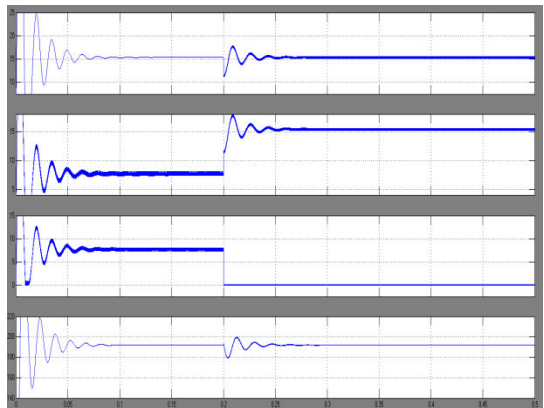

Fig. 13.simulated waveforms for the transition between single-phase control and two-phase interleaved control single-phase to two-phase interleaved modes.

Case 2: Proposed Converter Fed Induction Machine Drive

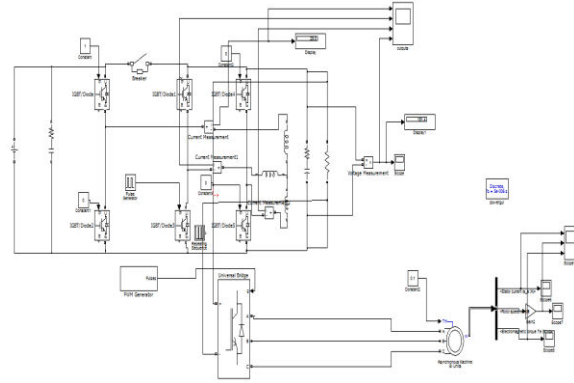

Fig.16 Matlab/Simulink Model of Proposed Converter Fed Induction Machine Drive

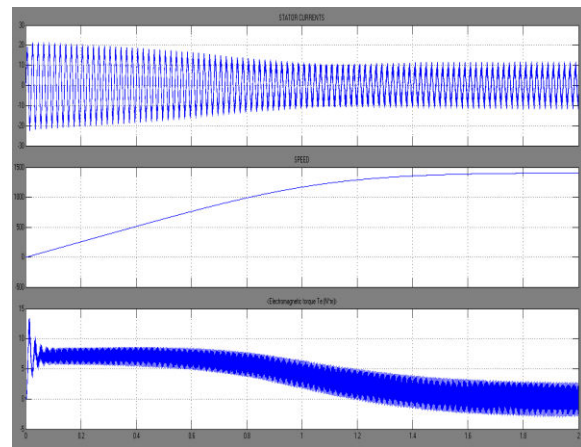

Fig.17.Stator Current, Speed, Electromagnetic torque of a Induction Motor.

IV. CONCLUSION

In this paper, a new converter topology has been proposed which has superior features over conventional topologies in terms of the required power switches and isolated dc supplies, control requirements, cost, and reliability. An HEV charges itself – it never has to be plugged in. When not in use

providing power, the motor can run as a generator to transfer energy from regenerative braking and from the gasoline engine to the batteries. The only recharging necessary is refueling by going to the gas station. Also, there is not the same demand on the batteries as there would be in an electric vehicle, where the batteries must store all the energy the car needs. Proposal of new integrated inverter/converter circuit of motor drives with dual-mode control for EV/HEV applications to significantly reduce the volume and weight, proposal of a new control method for the integrated inverter/converter circuit operating in boost converter mode to increase the efficiency, verification of the proposed integrated inverter/converter circuit. The above proposed converter tested by adding the induction motor and verified the speed torque characteristics.

REFERENCES

- [1] M. Ehsani, Y. Gao, S. E. Gay, and A. Emadi, *Modern Electric, Hybrid Electric, and Fuel Cell Vehicles*. Boca Raton, FL: CRC Press, 2005.
- [2] A. Emadi, M. Ehsani, and J.M. Miller, *Vehicular Electric Power Systems*: Land, Sea, Air, and Space Vehicles. New York: Marcel Dekker, 2003.
- [3] J. Larminie and J. Lowry, *Electric Vehicle Technology Explained*. New York: Wiley, 2003.
- [4] A. Y. Saber and G. K. Venayagamoorthy, "One million plug-in electric vehicles on the road by 2015," in *Proc. IEEE Intell. Trans. Syst. Conf.*, Oct. 2009, pp. 141–147.
- [5] M. Maskey, M. Parten, D. Vines, T. Maxwell, "An intelligent battery management system for electric and hybrid electric vehicles," *IEEE 49th Vehicular Technology Conference*, 2, 1999, pp. 1389–1391.
- [6] L. James and L. John, "Electric Vehicle Technology Explained", John Wiley & Sons, England. 2003.
- [7] M. Habib Ullah, M. T. Islam, Madeep Singh, N. Misran, "Design of A Microwave Amplifier for Wireless Application", *American Journal of Applied Sciences*, Volume 9, Issue 1, 2012, pp. 32-39.
- [8] Sharif M. Raihan, M. Habib Ullah, Riza Muhida, "A Prototype Design to Maintain Temperature and Humidity in an Open Compound Restaurant", *European Journal of Scientific Research*, Vol.63 No.2, 2011, pp.164-171.



- [9] M. Habib Ullah, Mandeep Sing, Sumazly Sulaiman, M. Shamim Shumon M. Islam, "Hardware Prototyping of Root Raised Cosine FIR Filter for 2x2 MIMO Channel Sounder", Australian Journal of Basic and Applied Sciences, 5(11), 2011, pp. 375-382.
- [10] M. A. P. Andrade, L. Schuch, and J. R. Pinheiro, "Generalized switching logic scheme for CCM-PFC interleaved boost converters," in Proc. IEEE Power Electron. Spec. Conf., 2004, pp. 2353–2359.
- [11] Y. Gu and D. Zhang, "Interleaved boost converter with ripple cancellation network," IEEE Trans. Power Electron., vol. 28, no. 8, pp. 3860–3869, Aug. 2013.
- [12] Y. T. Chen, S. Shiu, and R. Liang, "Analysis and design of a zero-voltage switching and zero-current-switching interleaved boost converter," IEEE Trans. Power Electron., vol. 27, no. 1, pp. 161–173, Jan. 2012.
- [13] T. Grote, H. Figge, N. Fröhleke, W. Beulen, F. Schafmeister, P. Ide, and J. Böcker, "Semi-digital interleaved PFC control with optimized light load efficiency," in Proc. IEEE Appl. Power Electron. Conf. , 2009, pp. 1722–1727.