

## MULTI-BAND MICROSTRIP ANTENNA DESIGN FOR TERAHERTZ COMMUNICATION SYSTEMS

Dr J. Srinkanth<sup>1</sup>, Mr.Sravan Kumar Mokka<sup>2</sup>

<sup>1</sup>Associate Professor, Department of CSE ,Malla Reddy Engineering College For Women,(Autonomous Institution), Maisammaguda,Dhulapally,Secunderabad,Telangana-500100

<sup>2</sup>Assistant Professor, Department of CSE ,Malla Reddy Engineering College For Women,(Autonomous Institution), Maisammaguda,Dhulapally,Secunderabad,Telangana-500100

### Abstract:

The purpose of this study is to investigate the performance of a circular patch antenna designed for 6G applications at the frequency range of 2.0723 THz to 4.1058 THz. A microstrip line feed was added in the design to mimic the behavior of the circular patch antenna. The antennas were fabricated using an FR4 substrate with a thickness of 1.6mm. This circular microstrip line feed antenna shows high performance with bandwidths of 1.4276 THz and 0.80908 THz. Some key parameters such as axial ratio, surface current, directivity, gain, and return loss have been analyzed. The antenna is designed to resonate at 10 different frequency bands. Thus, it is used for advanced wireless communication applications. It is especially useful for small, portable devices that support communication protocols.

**Keywords:** Microstrip line, Circular patch antenna, FR4 substrate, Return loss.

### 1. INTRODUCTION

The process of converting electrical power into radio waves using an electrical equipment known as an antenna. Often, it works in conjunction with a radio transmitter or receiver. To broadcast a signal, a transmitter feeds the antenna's terminals with a high frequency AC current that oscillates at radio frequencies. Then, to amplify it, this voltage is applied to a receiver. They are used in a wide range of devices, such as small monitor, cordless microphone, WIFI devices, cordless computer network, multiple radio, messaging receivers, radar, cell phones, and Radio - frequency identification on goods, in furthermore to systems like broadcasting, commercial television, and multiple radio. An antenna is a grouping of copper wires that are directly coupled to the wireless broadcast or the receivers. The oscillation electrons current of a transmission will create a rotating magnetic field around the antenna arrays, and the charge of the oscillating particles will create an induced electromagnetic field along the elements. In the latter case, an antenna could also incorporate extra parts or faces like horns, spherical reflections, or parasites features that are employed to concentrate wireless signals into a beam or other desirable radiation pattern but have no electronic signal between the transmission or the receivers. An electrical apparatus known as an antenna converts power generation into electrical signals and back again. Sometimes, antenna is used to refer to it. It accepts a signal from a twisted pair or other power cable and transforms it into radiant waves before transmitting it into space. It makes radio wave transmission and reception possible. A receiving

antenna, as contrast to a transmitting antenna, takes in radio waves from space, converts them into electrical impulses, and then transmits those signals to a transmission line.

## 2. MICROSTRIP CIRCULAR PATCH ANTENNA

In essence, a polymeric substrate with a beam and a buffer layer on either side makes up microstrip patch transmitters. The conducting elements copper and gold are frequently used to make patches. The patch is a mere wavelength above the ground plane and is very thin (between 0.003 and 0.05). ( $t$ , where  $t$  represents the wavelength in freespace. The microstrip patch is made to have a pattern that is as uniform as feasible. This is achieved by carefully selecting the stimulation mode beneath the patch. With typical dielectric constants ranging from 2.2 to 12, a variety of substrates can be used to create microstrip patch antennas. Even though they result in bigger generate value, thick surfaces with low electrical constant are chosen for antenna parameters because they provide superior efficiency, a wider bandwidth, and freely confined beams for transmission into space. Here between patch edge and the side of the substrate, fringing fields are the primary source of patch antenna microstrip emission. As frequencies, depth of penetration, and permeability are increased, the radiation generally arises from defects (Lewin, 1960) Good antenna quality and circuitry must be sacrificed since microchips are frequently linked with other microwave devices. Applying the photo-etched feed lines and radiating components to the dielectric substrate. Any form, including square, rectangle, thin strip (dipole), circular, elliptical, triangular, and more, can be used for the radiating patch. Using different polarizations, resonance frequencies, and impedances, a tiny strip antenna may be employed. It is appropriate for use in cellular and public surveillance equipment where restricted spectrum is required due to its operational features, which include limited capability, power dissipation, better quality factor, poor polarization purity, bad scanning performance, and severely limited frequencies bandwidth.

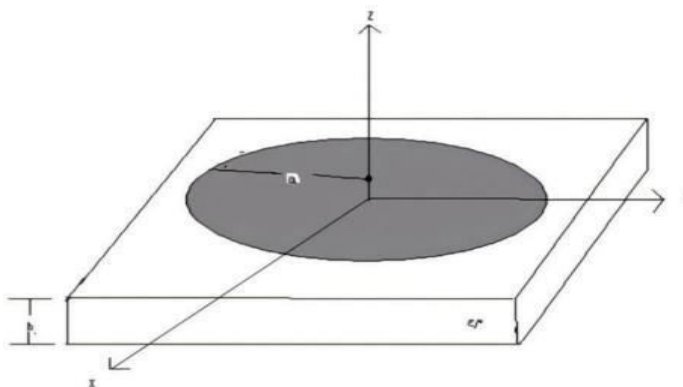

Figure. 1. Circular Patch Antenna

## 3. THEORY

### 3.1 EXISTING SYSTEM

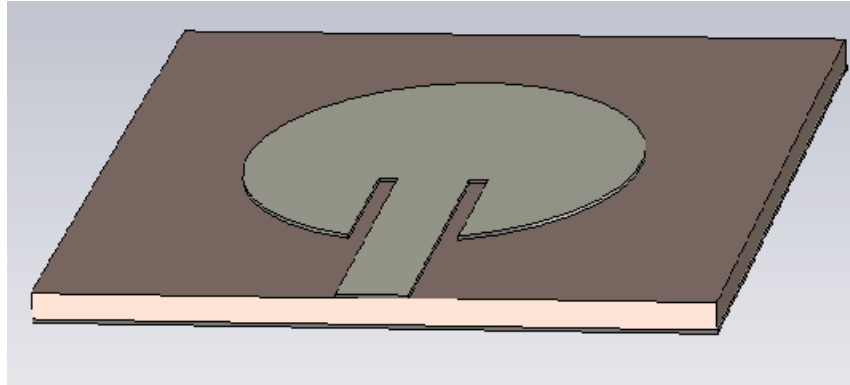

Figure. 2. The geometry of Microstrip Linefed Circular Patch Antenna

For 5G applications, the present technology employs a patch antenna with a circular form that resonates in the 28 GHz band. The structure of the antenna is made of RT/Duroid 5880. RT/Duroid 5880 has a thickness that ranges from 5.00 to 125mm and a dielectric constant of 2.2. A circular patch antenna with coaxial feeding technology provides fair return loss, directivity, and gain. Coaxial feed bandwidth for the patch antenna is 0.792 GHz at 28 GHz.

In the GHz was utilized in the current system because it had good return loss with microstrip line feeding, but it only provides a small bandwidth and is only appropriate for a particular application.

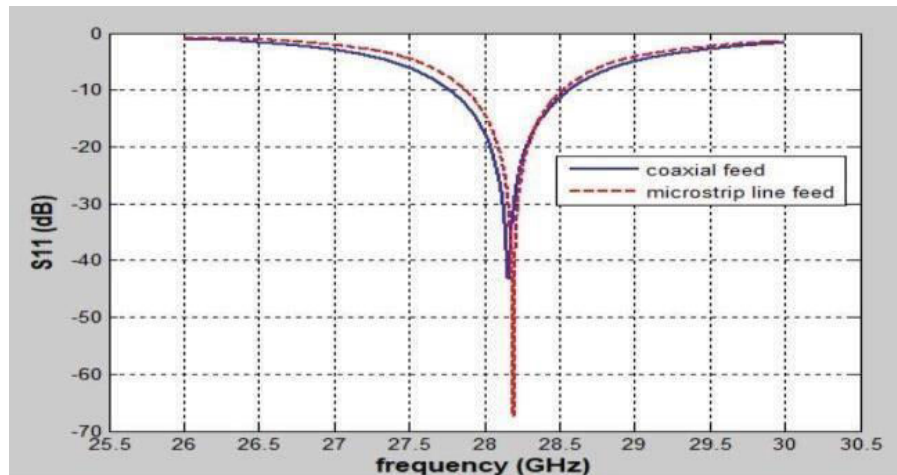

Figure. 3. Simulated return loss parameter

### 3.2 PROPOSED SYSTEM

The antenna designs we show in this research have properties that make them more suitable for THz transmission across short distances. Terahertz (THz) lines will be crucial for high data rate

transmission over a few meters. The proposed concepts are strong contenders for high-speed and short-range wireless communication systems because of the findings attained. Terahertz communication is suited to both stationary and moving users in both indoor and outdoor settings. Terahertz communication is carried out at the same pace through wired and wireless networks. THz and sub-THz frequencies have a few benefits, including antenna sizes that are reduced to around sub-millimeter sizes. It is less expensive, lighter, and smaller in size. Improved bandwidth, improved gain, directivity, and multi-frequency performance are among its features. It was proposed to employ THz for effective input impedance matching.

**Design:** Circular Shaped Patch Antenna

**Ground:** Truncated corners of Rectangular shaped partial ground

Here, we can see the dimensions and the shape of the rectangular shape circular patch antenna.

It is less expensive, lighter, and smaller in size. Improved bandwidth, improved gain, directivity, and multi-frequency performance are among its features. It was proposed to employ THz for effective input impedance matching.

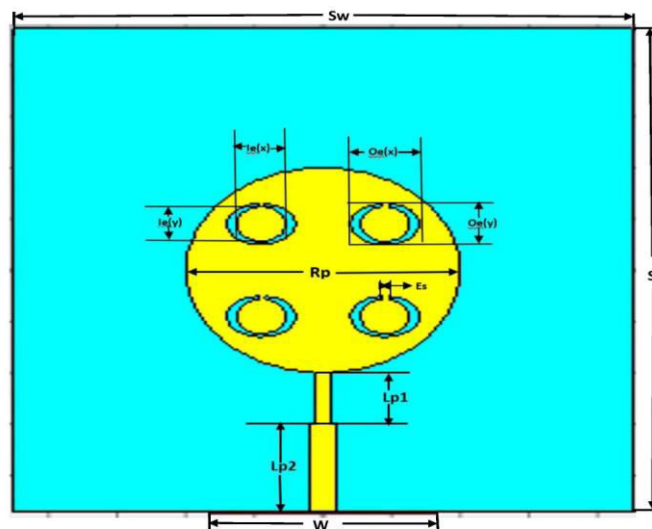

Figure. 4. Circular Patch antenna

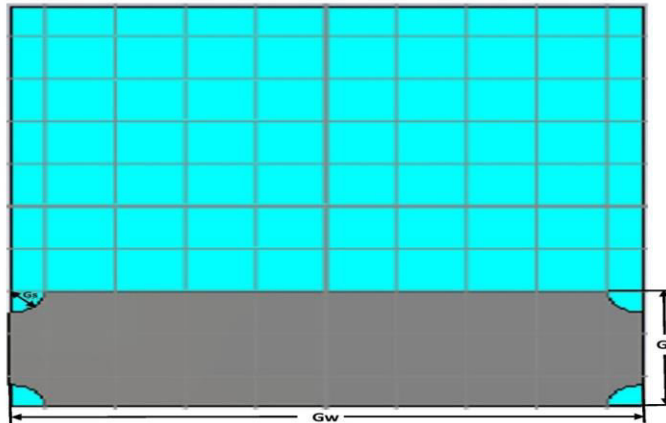

Figure. 5. Rectangular Partial Ground

**Dimensions:**

Parameter	Description	Value ( $\mu\text{m}$ )
G <sub>l</sub>	Length of the ground	135
G <sub>w</sub>	Width of the ground	450
G <sub>s</sub>	Slot radius of ground	20
S <sub>l</sub>	Length of the substrate	470
S <sub>w</sub>	Width of the substrate	450
R <sub>p</sub>	Radius of patch	100
L <sub>p1</sub>	Length of the patch 1	10
L <sub>p2</sub>	Length of the patch 2	20
I <sub>e(x)</sub>	Elliptical major axis 1	25
I <sub>e(y)</sub>	Elliptical minor axis 1	20

Oe(x)	Elliptical major axis 2	20
Oe(y)	Elliptical minor axis 2	18
Es	Split over the ellipse	4
Wf	Width of the feed	10

Table: 1 Dimensions of Circular shape patch antenna.

## 4. RESULTS AND CONCLUSION

### 4.1 RESULT

**Return Loss:** In this Result the designed circular patch antenna shows return loss value well below

#### S11 Results:

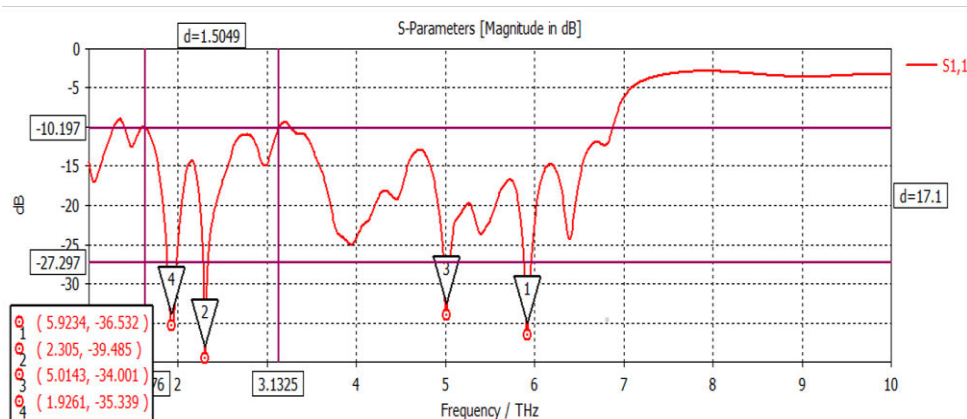

Figure. 6. Return loss at 5.9234 THz, S11 value is -36.5532dB, at 2.305 THz, S11 value is -39.485dB, at 5.0143 THz, S11 value is -34.001dB and at 1.9261 THz, S11 value is -35.339dB.

#### VSWR:

It is defined as ratio between transmitted and reflected voltage standing waves in a radio frequency (RF) electrical transmission system. It is a measure of how efficiently RF power is transmitted from the power source, through a transmission line, and into the load.

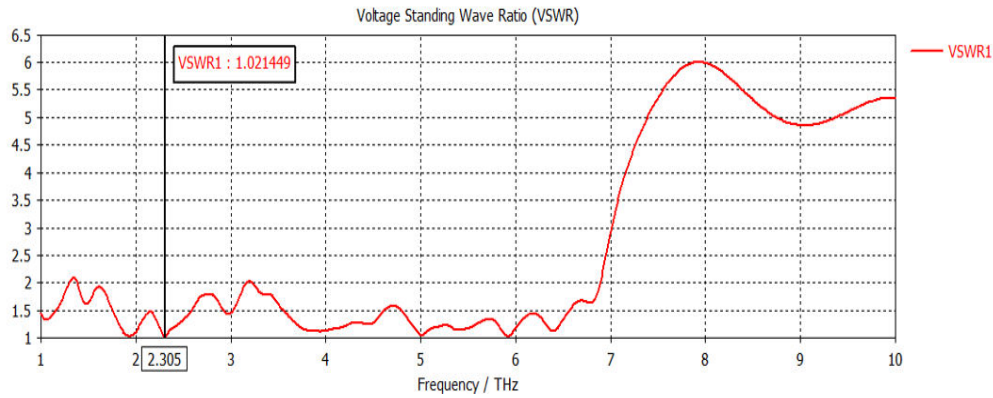

Figure. 7. VSWR at 2.305 is 1.02

**Applications:** Building and Factory automation.

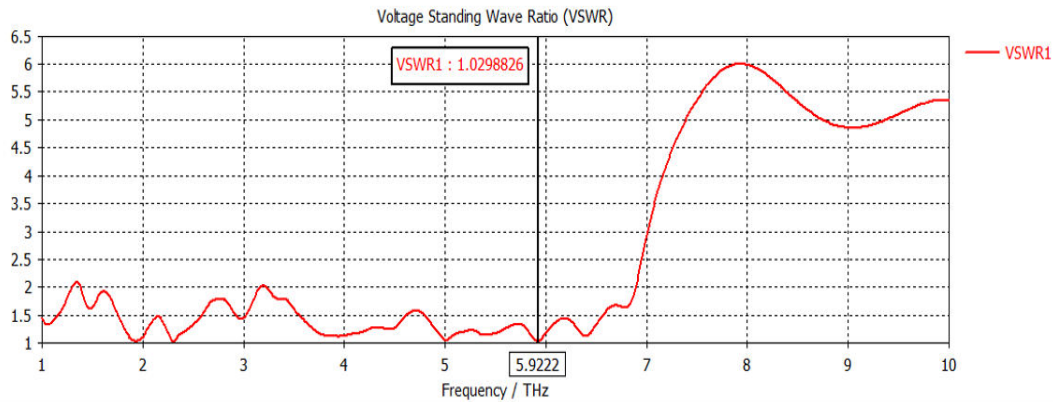

Figure. 8. VSWR at 5.922 is 1.02

**Applications:** Production and E-health.

**GAIN:**

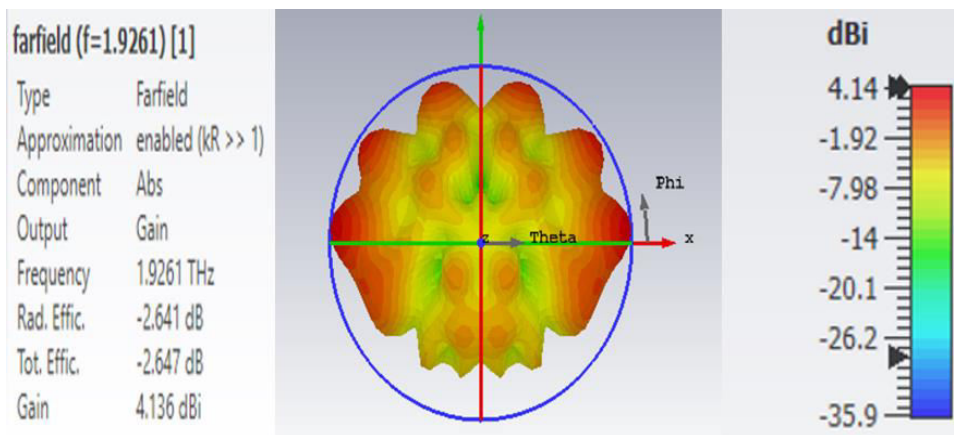

Figure. 11. Gain at f = 1.9261 is 4.136dBi

**Applications:** Remote patient monitoring and Wearable medical devices.

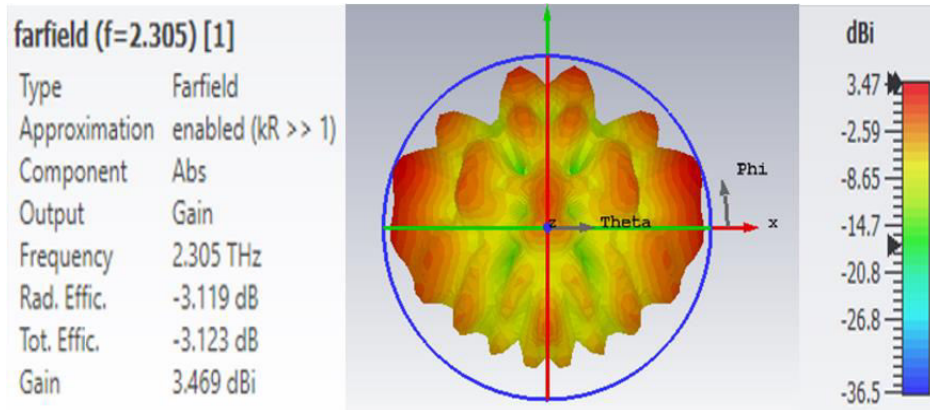

Figure. 12. Gain at f = 2.305 is 3.469dBi

**Applications:** Robotics and Telemedicine solutions.

**BANDWIDTH:**

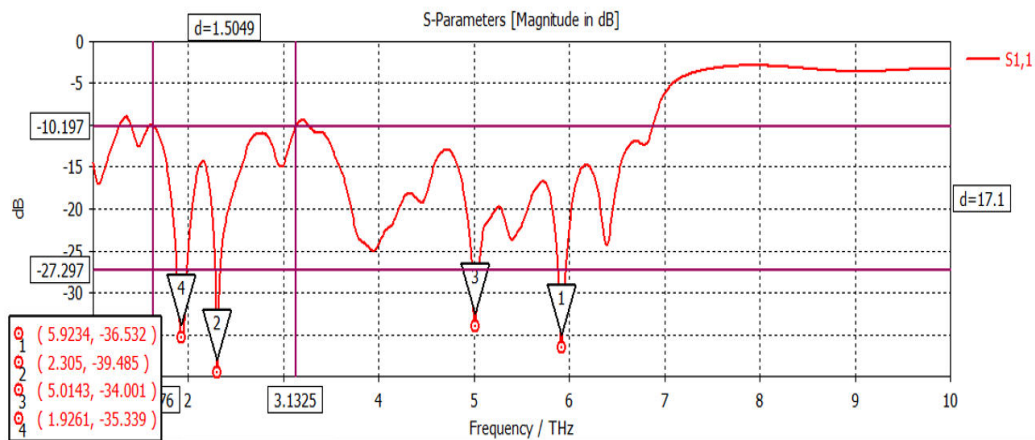

Figure. 13. Bandwidth at f = 2.305 is 1.5049 THz

**Applications:** Waste management and Water treatment.

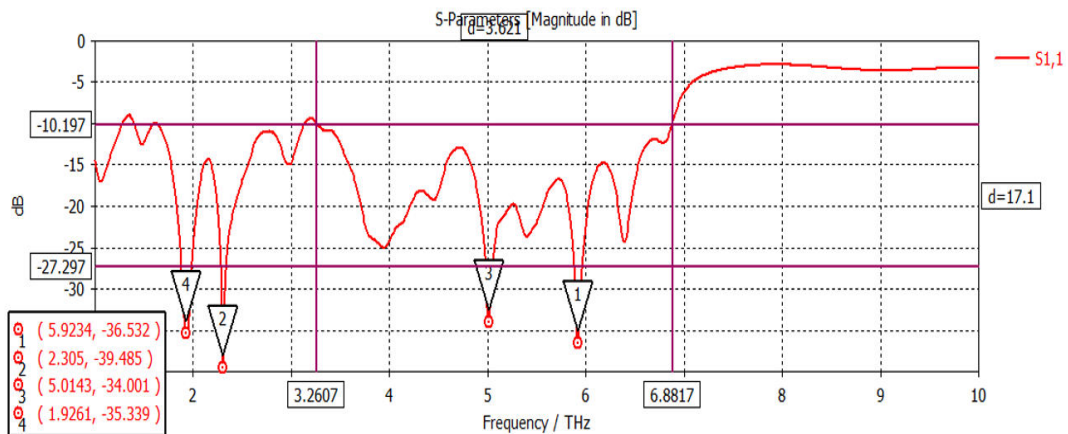

Figure. 14. Bandwidth at f = 5.9234 is 3.621THz



**Applications:** Precision health care and Earth monitor.

**DIRECTIVITY:**

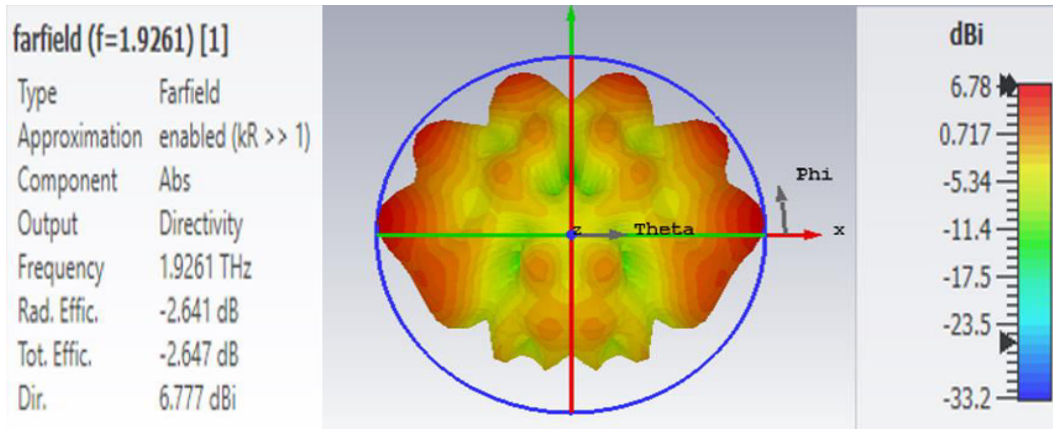

Figure. 17. Directivity at  $f = 1.9261$  is 6.777dBi

**Applications:** Broadband cellular networks.

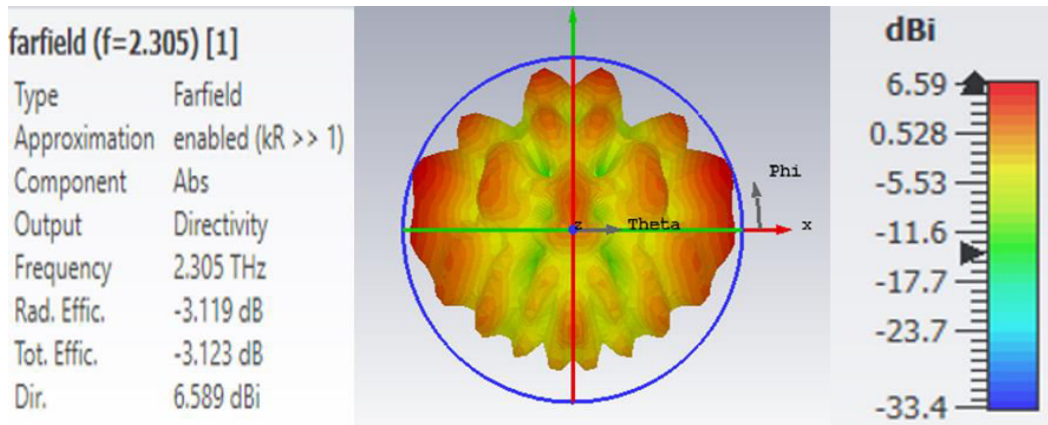

Figure. 18. Directivity at  $f = 2.305$  is 6.589dBi

**Applications:** Assistive Technology and Immersive AR/VR.

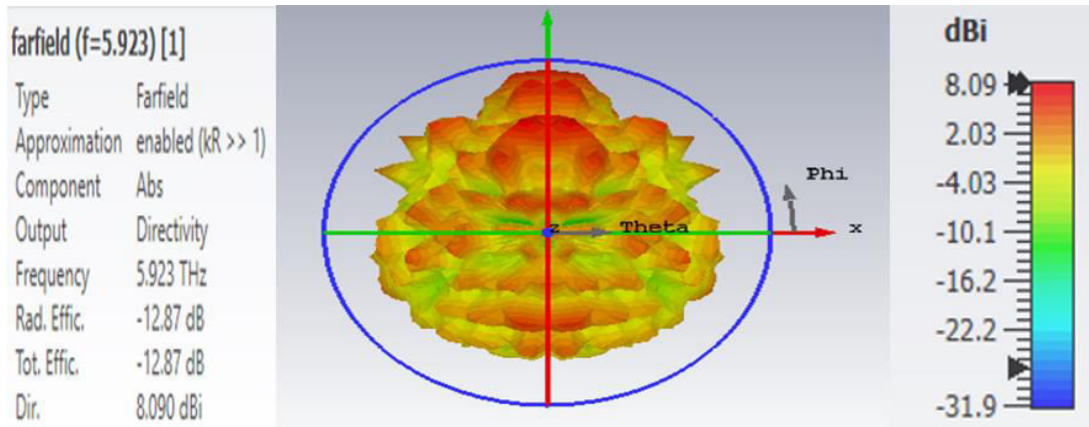

Figure. 20. Directivity at  $f = 5.923$  is  $8.090\text{dBi}$

**Applications:** Decentralized Businesses.

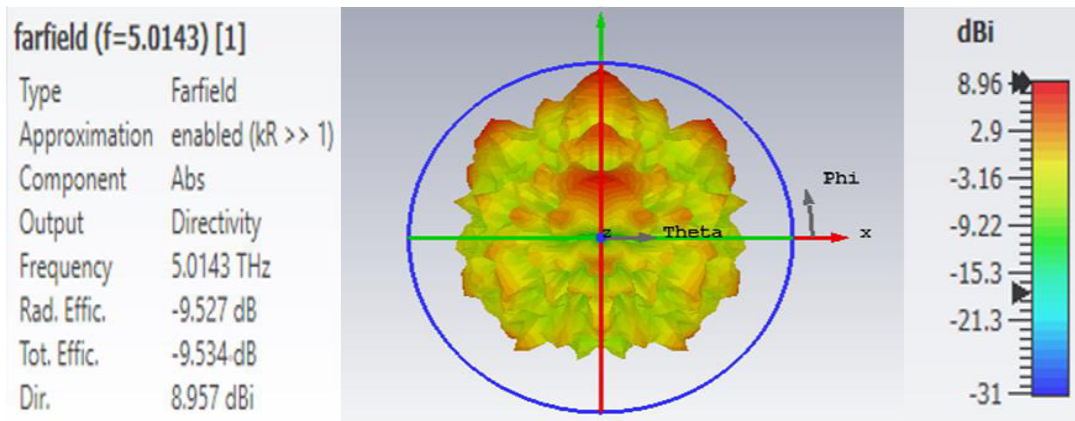

Figure. 19. Directivity at  $f = 5.0143$  is  $8.957\text{dBi}$

**Applications:** Advanced AI and Autonomous vehicles.

Parameter	Resonance Frequency $f = 5.9234$ THz	Resonance Frequency $f = 2.305$ THz	Resonance Frequency $f = 5.0143$ THz	Resonance Frequency $f = 1.9261$ THz
<b>S11(dB)</b>	-36.532	-39.485	-34.001	-35.339
<b>Directivity(dBi)</b>	8.090	6.589	8.957	6.777
<b>Gain (dBi)</b>	-4.778	3.469	-0.5698	4.136

<b>VSWR</b>	1.0298	1.0214	1.0419	1.0357
<b>Bandwidth (THz)</b>	3.621	1.5049	3.6112	1.5115

Table 2. Analysis of radiation characteristics for the proposed antenna designs

## 5. CONCLUSION

This study built and tested a recommended microstrip circular patch antenna for upcoming 6G applications at resonance frequencies of 2.07 THz and 4.105 THz. Using the outcomes of the proposed antenna, the performance of the suggested antenna for wireless applications is also assessed. The designed antenna has a higher gain for strong signal reception, more bandwidth for accessing, sharing, or downloading data, good return loss of -33.172dB and -28.313dB, and the necessary voltage standing wave ratio is effective for transmitting radio frequency power, which is essential for 6G applications and devices supporting 6G, such as smartphones. These traits are clearly visible in the outcomes of our simulation, which are displayed above.

## FUTURE SCOPE

Wideband width is needed in wireless scenarios to increase data rates, which could be achieved by defining: Slots, Fractals, various feeding mechanisms, Size of the port and the antenna.

## 6. REFERENCES

- [1] Deschamps, G.A., "Microstrip Microwave Antennas", Third symposium on the USAF Antenna Research and development program, University of Illinois, Moticello, Illinois, October 18-22, 1953.
- [2] Bernhard, J.T., Mayes, P.E., Schaubert, D., and Mailoux, R.J., "A commemoration of Deschamps' and Sichak's 'Microstrip Microwave Antennas': 50 years of Development, divergence, and new directions," Proceedings of the 2003 Antenna Applications Symposium, Moticello, Illinois, September 2003, pp. 189-230 Randy Bancroft, 2nd edition,"
- [3] "Circuits-a historical survey," IEEE Transactions on microwave Theory and techniques, vol.3, No.2, pp. 1-9.
- [4] Denlinger, E.J., "Radiation from Microstrip Radiators" IEEE Transactions on microwave Theory and techniques, April 1969, vol.17, No. 4, pp. 235-236.