



International Journal for Innovative Engineering and Management Research

A Peer Reviewed Open Access International Journal

www.ijiemr.org

COPY RIGHT



ELSEVIER
SSRN

2019 IJIEMR. Personal use of this material is permitted. Permission from IJIEMR must be obtained for all other uses, in any current or future media, including reprinting/republishing this material for advertising or promotional purposes, creating new collective works, for resale or redistribution to servers or lists, or reuse of any copyrighted component of this work in other works. No Reprint should be done to this paper, all copy right is authenticated to Paper Authors

IJIEMR Transactions, online available on 23rd Dec 2019. Link

[:http://www.ijiemr.org/downloads.php?vol=Volume-08&issue=ISSUE-12](http://www.ijiemr.org/downloads.php?vol=Volume-08&issue=ISSUE-12)

Title: **MOTION ANALYSIS OF SWITCH GEAR**

Volume 08, Issue 12, Pages: 442-446.

Paper Authors

B.SUDHAKARA RAO, DR MD ABID ALI, V SAI SURENDRA, G.V.SUBASH

Ramachandra College of Engineering, Eluru, A.P, India



USE THIS BARCODE TO ACCESS YOUR ONLINE PAPER

To Secure Your Paper As Per **UGC Guidelines** We Are Providing A Electronic Bar Code

MOTION ANALYSIS OF SWITCH GEAR

B.SUDHAKARA RAO¹ | DR MD ABID ALI² | V SAI SURENDRA³ | G.V.SUBASH⁴

¹ Department of Mechanical Engineering, Ramachandra College of Engineering, Eluru, Andhra Pradesh, India.

² Professor-MED, PSCMR College of Engineering and Technology, Vijayawada

^{3,4} Department of Mechanical Engineering, Ramachandra College of Engineering, Eluru, Andhra Pradesh, India.

baluvurisudhakar@gmail.com

ABSTRACT

In this paper, the main function of a circuit breaker is to open up a circuit for a pre-defined time so as to prevent a sudden surge in current that could damage the equipment due to high heat is discussed. The equations of motion derived in this paper can predict the closing, opening of spring type operating mechanism in predefined time as well as be used to compute dynamic response of the moving contact. Using the optimized switch gear mechanism, the atlas of all feasible mechanisms for the spring-actuated controlling system of a circuit breaker has been synthesized.

KEYWORDS: Circuit breaker, multi body dynamic analysis, switchgear, Switch on/off spring. , FEA, ANSYS

I. INTRODUCTION

The dynamic response of circuit breakers can also be analysed using multi-body dynamics. This method is particularly important in analyzing the dynamics of complicated mechanisms. Basically, multi-body system is an assemblage of rigid machine members, the members which produce relative motions due to constraints. In multi-body dynamics, Lagrange equation is usually employed to derive a set of second order non-linear differential equations that are subsequently solved by numerical methods. However, the number of differential equations increases exponentially with increasing complexity. Not only does the derivation process become tedious, the computing time also increases significantly when solving these equations numerically. The spring type operating mechanism for a SF₆ gas insulated circuit breaker, mechanism has 2 degrees of freedom (DOF). When working in open, Close or return modes by fixing a link that adjoins the frame it transforms into single – DOF

system. In this manner motion requirements can be achieved and the characteristics of the structure and its resulting complex motions can be analyzed. Several different classifications of switchgear can be made.

- By the current rating.
- By interrupting rating
- Circuit breakers can open and close on fault currents
- Load-break/Load-make switches can switch normal system load currents
- Isolators may only be operated while the circuit is dead, or the load current is very small.

II. PRINCIPLE OF CIRCUIT BREAKER

In the close operation, as illustrated in Figs. 1 and 2, [7] link 7 is locked by the tripping latch and hence, remains stationary. Link 2 is the follower of the driving cam, and link 6 generates the output motion.

In open operation, a positioning pin prohibits link 2 from rotating counterclockwise. As the tripping latch is turned on, the tripping spring rotates link 6. At the same time, link 7 is rotated clockwise from the effect of the tripping spring. In return operation, the higher spring constant of the tripping spring than that of the returning spring stops link 6 from rotating, while link 2 is rotated clockwise by the returning spring. This type of circuit breaker is particularly useful in power supply systems where unpredictable situations may arise. In undesirable circumstances, the tripping and closing springs in this circuit breaker, which are constantly in the ready mode, can be manually overridden to perform the sequence 'open-return-close- open-return in an instant. The emphasis here is that it can produce two open operations at any one time, making them safer and more reliable.

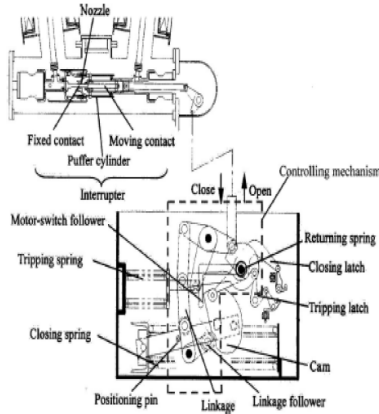

Fig. 1 : Gas insulated circuit breaker

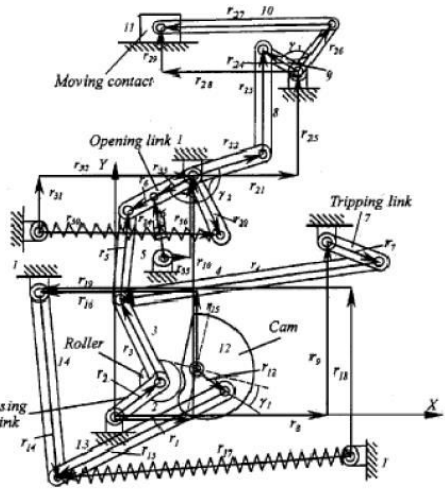
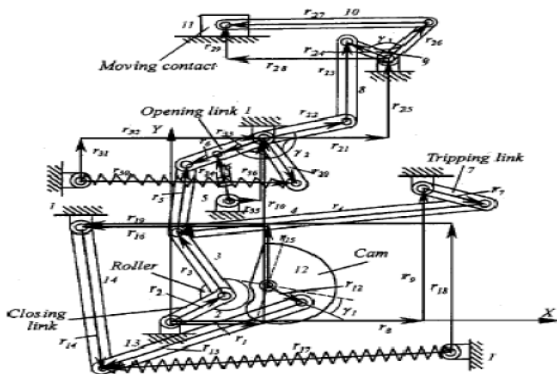

Fig. 2 : Vector loop diagram

Fig. 3 : Schematic of switch gear mechanism

III. SWITCH GEAR DESIGN

The Circuit breaker has following topological characteristics

- The controlling mechanism consists of eleven links and fourteen revolute joints, two of which form a multiple joint and the mechanism is thus considered as having two degrees-of -freedom(dof)
- In each of the three basic operation, by fixing an arbitrary link that adjoins the fixed link, the mechanism is reduced to a ten-member linkage consisting of thirteen revolute joints, two of which controlling mechanism for a circuit breaker has 2-dof. In the close, open, and return operations, different links are fixed to achieve the desired motions, which is analogous to

the fixing of different links in the planetary gear train to attain the desired speed ratio [4]

Table 1: Status of switch Gear Mechanism

Operation	Closing link	Opening Link	Returning link	Closing spring	Trip spring	Returning spring
Close	Input	Motion	Fixed	Released	Compressed	Fixed
Open	Fixed	Input	Motion	Fixed	Released	Compressed
Return	Motion	Fixed	Input	Motion	Fixed	Released

IV. KINEMATIC ANALYSIS

For the close operation, spring drives the cam via a link and cam in turn drives the follower, to close up the moving and the fixed contact while compressing the switch of and contact springs. The cam rotates about 180°. The roller follower is followed the cycloid motion, which is being mostly used for high speed applications, the roller follower motion optimized one [7] is considered for the analysis. Hence the input values of follower angular displacements have been applied from this paper as given in the Fig-4.

As this follower motion is the oscillation type, with the radius equal to its length, the lift (s) of the follower can be found for the maximum rotation of the cam. Angular displacement can also be found as follows using equations extracted from the paper.

Once after knowing the angular rotation of the follower, its angular velocity and angular accelerations can be found by differentiating with respect to the closing time intervals. This follower angular displacement curve (Fig-4) can be suitably fit in to the fourth order equation with the help of MATLAB.

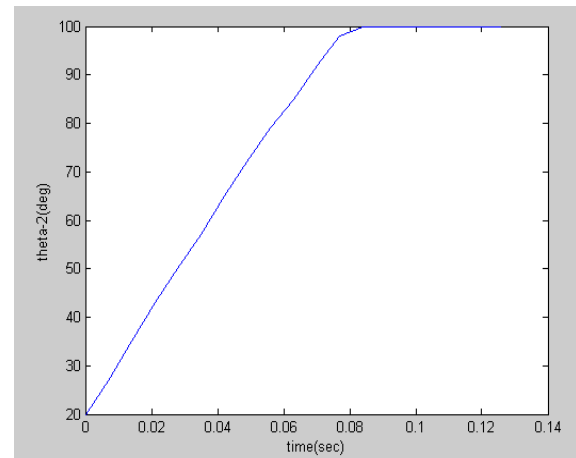

Fig. 4: Follower angular displacement

Opening:

Similarly for opening operation, the various link rotation angles can be found by considering the same equations which are used for closing operation of the switch gear mechanism. However the link 2 remains fixed for opening operation.

V. RESULTS AND DISCUSSION

The initial positions of the circuit breakers mechanism are obtained through kinematic analysis by considering the system to be initially stationary and the numerical method applied by using MATLAB. The analyzed results for the close and operations are shown in Fig.5 through 6.

The displacement of the moving contact during closing is 0.089 m and the operating time of the circuit breaker is 0.13 sec. The numerical results are comparable with the results shown by the Fu-Chen Chen [8].

The time period of operation is in the order of milli seconds to avoid arcing. This is difficult to observe with a naked eye. The mechanism has been simulated and verified for its operating time [0.08 sec]. Results from Ansys and solid works are comparable. The deviation in the results is due to the absence of dampers and torsion spring. The maximum velocity of the moving contact is 4 m/s and the obtained values are within the limit. Multi body systems have conventionally been modeled as rigid body systems with superimposed elastic effects of one or more components. A major limitation of these methods is that nonlinear

large-deformation, finite strain effects, or nonlinear material cannot be incorporated completely into model. The finite element (FE) method is used for modeling a multi body system. It has the following advantages:

- The finite element mesh automatically represents the geometry while the large deformation/rotation effects are built into the finite element formulation.
- Inertial effects are greatly simplified by the consistent mass formulation or even point mass representations. Interconnection of parts via joints is greatly simplified by considering the finite motions at the two nodes forming the joint element.

The parameterization of the finite Rotation has been well documented in the literature and can be easily incorporated into the joint element formulations thereby enabling complete simulation of multi body system. Geometric properties of switch gear mechanism elements are width of the links 2 through 9 is 12 mm and the thickness is 4 mm. The link 10 is considered as the hollow cylinder rod having outside diameter 33.7mm and inside diameter 26.65mm. The moving contact mass is 0.5kg.

The tripping-off spring dimensions are as follows:

- Spring wire diameter : 5mm
- Outside coil diameter : 47mm
- Inside coil diameter : 37mm
- Free length :200 mm
- Number of active coils :12
- Load at mounting length on the spring : 244 N;
- Load at working length on the spring : 700 N;
- Stiffness of the spring : 10.54 N/mm;
- Material : IS 4454 with black coated finish

The Switch gear mechanism elements considered as beams, the connections between them as revolute

pairs and the moving contact as a concentrated mass, the whole system as multi body system has been analyzed by using ANSYS software. The Finite element model of the switch gear mechanism is shown in **Fig.5**.

The results related to linear displacement, Linear velocity, linear acceleration of Link 11 Closing Operations and Open operation of Link 11 are shown in **Fig.6** and **Fig.7**.

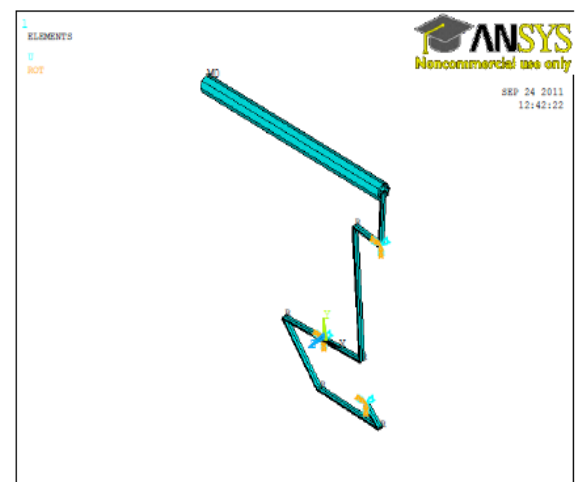

Fig. 5: ANSYS of Switch Gear

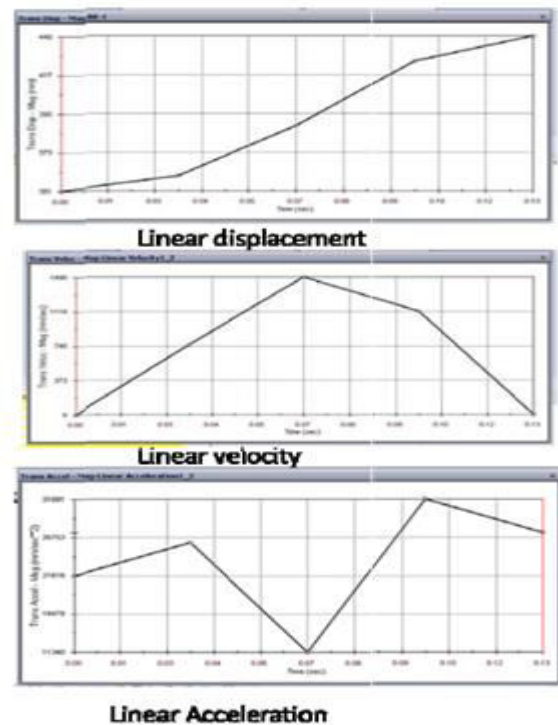

Fig.6.Link11 closing operations

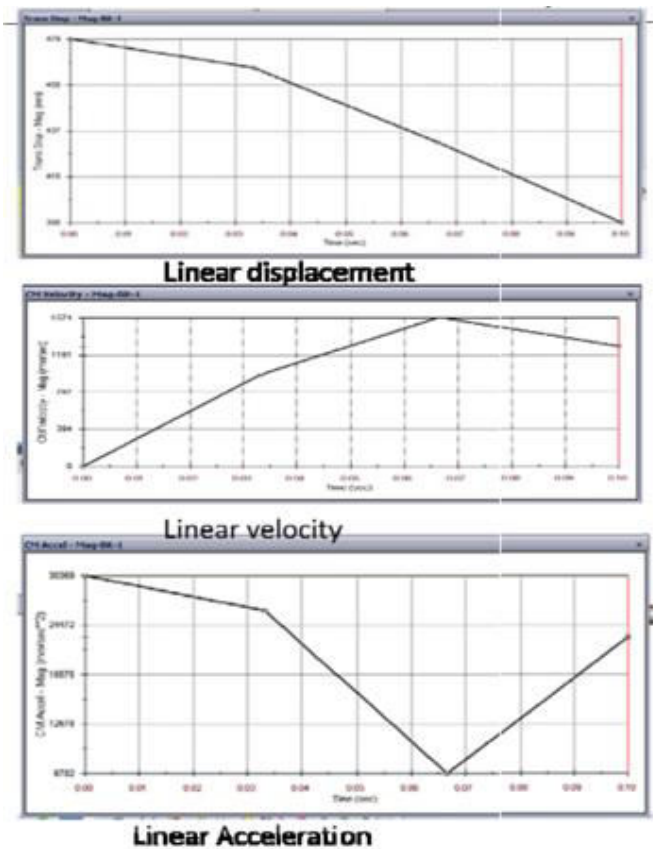

Fig. 7 : Open operation of Link 11

ACKNOWLEDGEMENTS

The authors would like to thank the anonymous reviewers for their comments which were very helpful in improving the quality and presentation of this paper

REFERENCES

- [1] Chen, F. C., and Hsu, M. H., 2001, "On the Transmission Efficiency of Spring-Type Operating Mechanism for SF6 Gas Insulated Circuit Breakers," *J. Mech. Eng. Sci.*, 215(10), pp. 1239–1249.
- [2] Fu-Chen Chen, "Dynamic response of spring-type operating mechanism for 69 KV SF6 gas insulated circuit breaker," *Mechanism and Machine Theory*, Volume 38, 2003, Pages 119- 134.
- [3] Greenwood, D. T., 1988, *Principles of Dynamics*, Prentice-Hall, Inc., Englewood Cliffs, New Jersey

- [4] C.C. Jobs, G.M. Palmer, K.H. Means, "Synthesis of a controllable circuit breaker mechanism," *Journal of Mechanical Design* 112(3),(1990),324-330
- [5] Freudenstein, F., and Maki, E. R., 1979, "The Creation of Mechanisms According to Kinematic Structure and Function," *J. of Environmental and Planning B*, 6, pp. 357–391
- [6] Freudenstein, F., and Maki, E. R. 1983 "Development of an Optimum Variable Stroke internal Combustion Engine Mechanism from View Point of Kinematic Structure," *ASME J.Mech., Transm. Autom. Des.*, 105, pp.259–266.
- [7] Tsai, L. W., and Lin, C. C., 1989, "The Creation of Non fractionated Two Degree-Freedom Epicyclic Gear Trains," *ASME J.Mech Transm., Autom.Des.*, 111(4), pp. 524–529.
- [8] Jobs, C. C., Palmer, G. M., and Means, K. H., 1990, "Synthesis of a Controllable Circuit Breaker Mechanism," *ASME J. Mech. Des.*, 112(3), pp. 324–330.
- [9] Root, R. R., and Ragsdell, K. M., 1983, "Circuit Breaker-A Practical Example in Engineering Optimization," *Mech.Mach Theory*, 18(3) pp.229-235