



COPY RIGHT



ELSEVIER
SSRN

2023 IJIEMR. Personal use of this material is permitted. Permission from IJIEMR must be obtained for all other uses, in any current or future media, including reprinting/republishing this material for advertising or promotional purposes, creating new collective works, for resale or redistribution to servers or lists, or reuse of any copyrighted component of this work in other works. No Reprint should be done to this paper, all copy right is authenticated to Paper Authors

IJIEMR Transactions, online available on 25th JUN 2023. Link

[:http://www.ijiemr.org/downloads.php?vol=Volume-12&issue=Issue 06](http://www.ijiemr.org/downloads.php?vol=Volume-12&issue=Issue 06)

10.48047/IJIEMR/V12/ISSUE 06/07

Title **SMART HELMET**

Volume 12, ISSUE 06, Pages: 42-46

Paper Authors **M. Sai Kiran, G. Naveen, T. Vamshi Krishna, V. Balanarsimha**



USE THIS BARCODE TO ACCESS YOUR ONLINE PAPER

To Secure Your Paper As Per **UGC Guidelines** We Are Providing A Electronic Bar Code

FIRE SENSING ROBOT USING ARDUINO

M. Sai Kiran¹, G. Naveen¹, T. Vamshi Krishna¹, V. Balanarsimha²

^{1,2}Department of Electrical and Electronics Engineering

^{1,2}Kommuri Pratap Reddy Institute of Technology, Ghatkesar, Hyderabad.

ABSTRACT

Fires are one of the most widespread causes of deaths by accident. Instant alerting to the fire department is necessary to ensure immediate action. Every minute can save many lives in such situations. So here we propose a robot which is roaming around the industry with an automatic fire department alerting system that instantly and automatically alerts the fire department and informs about the situation so that immediate action can be taken. The system uses Fire sensor to efficiently detect fires and alert fire department over Alarm. We use an Arduino uno in order to check if a sensor is triggered. Then it reconfirms if it really is a fire outbreak using temperature sensors in order to confirm of fire outbreak. The system now displays the fire incident with alarm buzzer in the fire department over internet so that the fire department personnel are alerted about the incident to take necessary action.

Keywords: Fire sensing robot, Arduino, Fire accidents.

1. INTRODUCTION

The security of home, laboratory, office, factory, and building is important to human life. We develop an intelligent multi sensor-based security system that contains a firefighting robot in our daily life. The destructive burnt cause by electrical is the highest source. It is because security system can't detect abnormal and dangerous situation and notify us. Besides, user had difficulties to detect the small burnt cause by electrical appliances. User may take a late time to extinguish fire like finding the water source to extinguish fire when want to extinguish the fire. The fire difficulties to detect the small burnt area and location that is hard to be reach by the user Sometimes tough fire extinguished for example spaces are hard to see. So, "Autonomous Fire Protection Robot With Notification" design with extinguisher for the intelligent building to controlled by microcontroller PIC18F4550 and supported by autonomous board CYTRON SK40C board and another additional circuit. This robot equipped with flame sensor where each sensors has its own function and commanded control by PIC18F4550. This robot will move to the fire source when the flame sensor detected the fire and it will send message to any phone of the GSM network through the modem connected to the programmable device.

This robot also programmed to stop before the robot hit the flame. This robot also can extinguish fire at 45 degree for upper side and 45 degree for lower side. This robot implicated the function of finger to clip the fire extinguisher clipper. The main aim of this project to sense and extinguish fire automatically. Robots are intelligent machines that may be use per need. This Project our fundamental goal is to style a model that will be able to sense and extinguish the fire. When fire occurs in building, factories or any places. Fighting with fire is sort of risky for fire fighters collectively may get trapped in such places. In such cases, the robot may be very efficient for fire fighting there's no need for human to travel even near the world blazing. Robot accommodates flame sensor, microcontroller, smoke sensor, motor driver, water tank, pump etc. Flame sensor is employed for to detect the hearth or to sense the warmth. Motor driver can get the instruction from microcontroller and followed that instruction for drive the motor of robot. The many types of controller are available for example 8051,

8052, 9 ATmega328, AVR etc. from this we can choose Arduino as a controller because it is more efficient and having less cost. This paper describes researches on fire fighting robot. In modern days the fire can be exist any time ,any where because of weather effect , in chemical industries ,high temperature working industries , by gas leakage etc. for those reasons the fire is exist that affect human being as well as animals to avoid this situation it need a robot that extinguish the fire. For design such kind of robot it required controller and processor that help the robot to control all the parts of robot.

Now such types of robots are already designed. Those robots are use different methods and techniques to extinguish the fire for example with the help of fan to extinguish the fire. The main factor is to detect the fire with the help of sensing devices like IR sensor, flame sensor, ultrasonic sensor etc. The robot work automatically so the behavioural of robot can change any time for that we uses the android application via the Bluetooth transmission to control the robot manually.

2. LITERATURE SURVEY

A robot is an automated device which performs functions usually attributed to humans or machines tasked with repetitive or flexible set of actions. Numerous studies have shown that robot can be beneficial in medicine, rehabilitation, rescue operation and industry. Over the years, robotics has been introduced in various industries. The industrial robots are multi-function manipulators designed for more specialized materials, divisions, gadgets or devices through various programmatic movements to perform various tasks. In line with the Fourth Industrial Revolution (4IR), there is demand for a one system that can control, communicate and integrate different robots regardless of their types and specifications.

Machine learning has also heated up interest in robotics, although only a portion of recent development in robotics can be associated with machine learning. Recent robotic development project has embedded machine learning algorithms to increase the intelligence in robots. This will increase the productivity in industry while reducing the cost and electronic waste in a long run. Studies on the use of humanoid robots are actively carried out to minimize firefighters' injuries and deaths as well as increasing productivity, safety, efficiency and quality of the task given. Robot can be divided into several groups such as Tele-robots, Telepresence robots, Mobile robots, Autonomous robots and Androids robots. Telepresence robot are similar to a telerobot with the main difference of providing feedback from video, sound and other data. Hence, tele-presence robots are widely used in many fields requiring monitoring capability, such as in child nursery and education, and on improving older adult's social and daily activities. Mobile robot is designed to navigate and carry out tasks with the intervention of human beings. Meanwhile, autonomous robots can perform the task independently and receive the power from the environment, as opposed to android robots which are built to mimic humans. In this paper, a firefighting robot is proposed. The main function of this robot is to become an unmanned support vehicle, developed to search and extinguish fire. There are several existing types of vehicles for firefighting at home and extinguish forest fires. Our proposed robot is designed to be able to work on its own or be controlled remotely. By using such robots, fire identification and rescue activities can be done with higher security without placing fire fighters at high risk and dangerous conditions. In other words, robots can reduce the need for fire fighters to get into dangerous situations. Additionally, having a compact size and automatic control also allows the robot to be used when fire occurs in small and narrow spaces with hazardous environments such as tunnels or nuclear power plants.

Thermite and FireRob are two current available fire fighter robots that have been used widely in industry. Thermite (produced by Howe and Howe Technologies Inc) is a firefighting robot that uses a remote control and can operate as far as 400 m. It can deliver up to 1200 gpm of water or 150 psi of foam. The size of this robot is 187.96 cm x 88.9 cm x 139.7 cm. This robot powers up to 25 bhp (18.64 kW) using a diesel engine. The main component in the design of this robot are multi-directional nozzle that is backed by a pump that can deliver 600 gpm (2271.25 l/min). This robot is designed for use in extreme danger areas, such as planes fires, processing factories, chemical plants or nuclear reactors.

3. PROPOSED SYSTEM

The function of fire sensing robot is same as the ordinary robot only the advancement is to detect the fire. The brain of this project is that the Arduino, but in order to sense fire we use fire sensor modules (flame sensor) We detect the direction of the fire we are able to use the motors to maneuver near the fire by driving our motors through the L293D module. When near a fire. The supply is mostly ordinarily injected to voltage consuming component, less typically to mechanical parts, and barely other parts. In this device a 12V DC power is offer to all electronics related component.

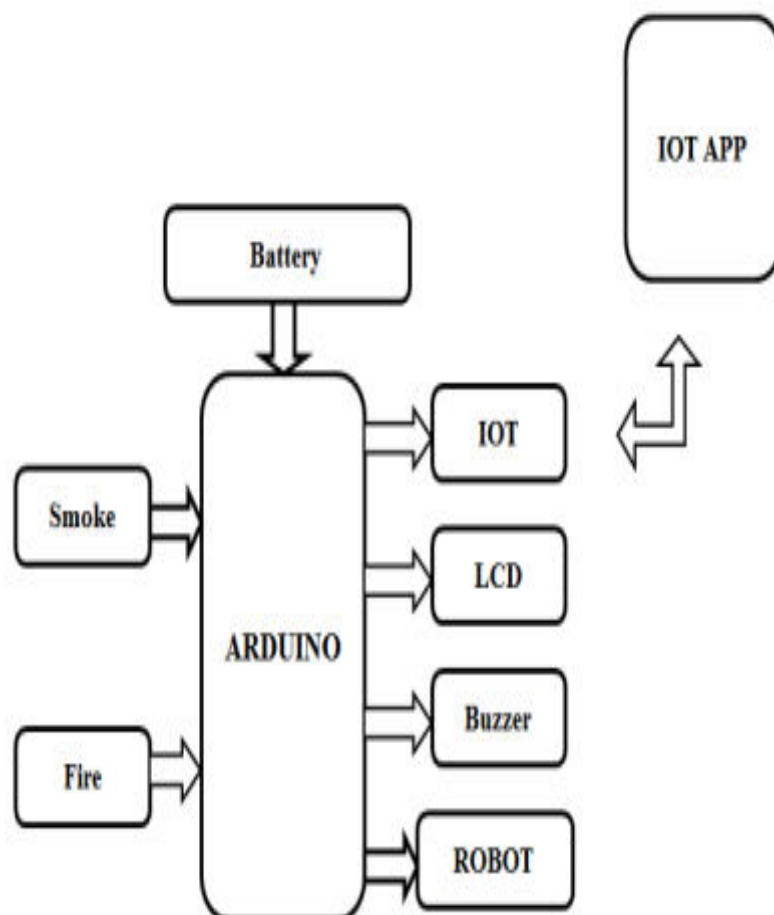

Fig. 1: Block diagram.

For this purpose, there is a requirement to step down electrical device, rectifier, transformer, and filter circuit for smoothing generated 12V DC power. When the fire detected, Robot will stop and automatically alert using Buzzer Module.

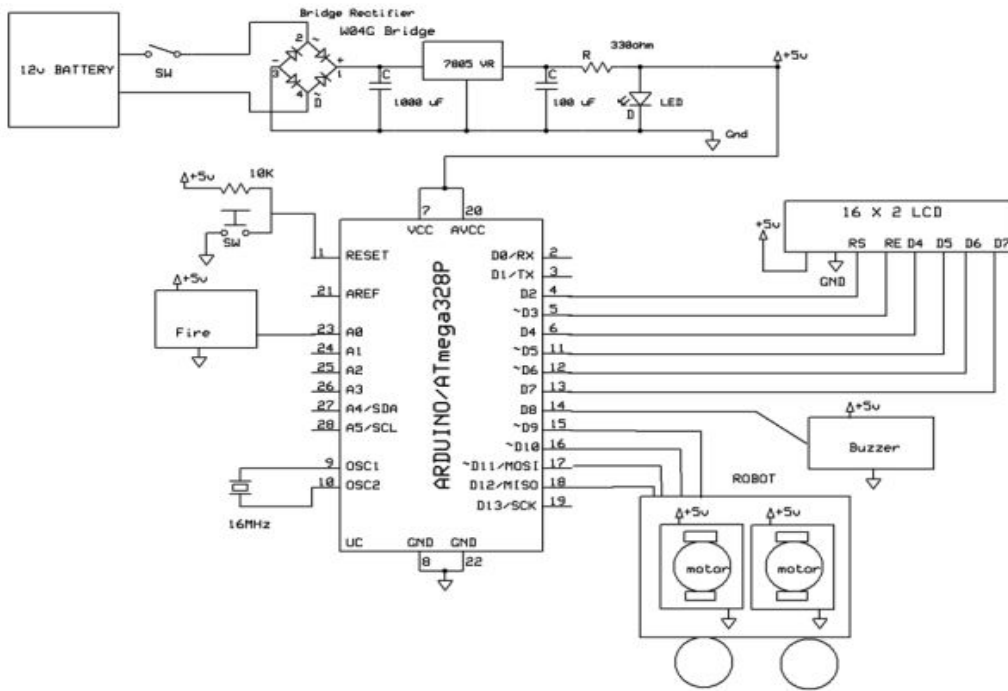
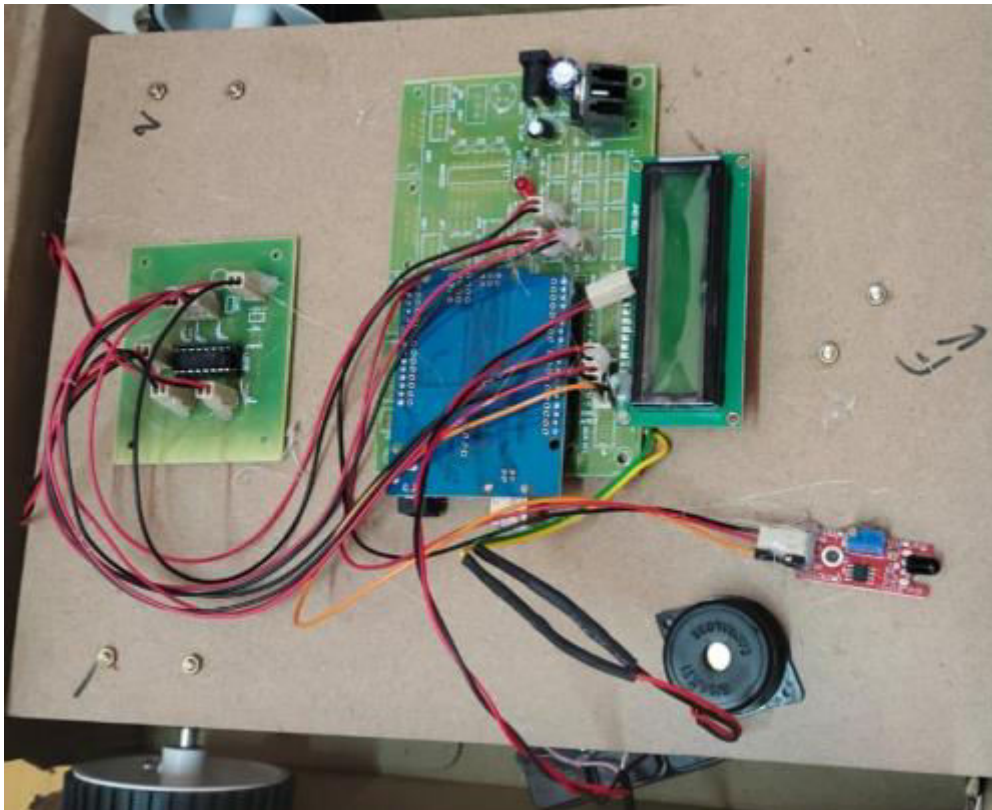

Fig. 2: Schematic diagram.

Fire sensing robot designed to detect fire and immediately alerts buzzer. Design and construction of this robot involve usage and integration of Arduino, FIRE sensor, L293D motor driver and DC motors. All these components are mounted on a motor chassis.

4. RESULTS



5. CONCLUSION AND FUTURE SCOPE

This paper concludes that the usages of fire detecting robots are very much safer and economical compared to manual methods in industrial. The principle of fire detection system using fire sensor is seen here. IoT based firefighting robot designed to detect fire and immediately robot will stop and alert you using buzzer. To implement this function, we need to integrate different sensors and systems together. Design and construction of this robot involve usage and integration of Arduino, FIRE sensor, L293D motor driver and DC motors. It is also seen that the notification in case of any FIRE is sent to the concerned authority through buzzer or alarm. We are going to design a low-cost Microcontroller Based Android controlled Robot.

Future Scope

In future studies this system integrates with GPS to get the exact location of fire and gas detection detected. The module utilizes an interface GPS sensor to transmit area of the leakage over to the IOT login system, here we use IOT to check, get and show the gas leakage caution and location over IOT.

REFERENCES

- [1] P. Zheng et al., "Smart manufacturing systems for Industry 4.0: Conceptual framework, scenarios, and future perspectives," *Frontiers of Mechanical Engineering*. 2018, doi: 10.1007/s11465-018-0499-5.
- [2] A. Glória, F. Cercas, and N. Souto, "Design and implementation of an IoT gateway to create smart environments," in *Procedia Computer Science*, 2017, doi: 10.1016/j.procs.2017.05.343.
- [3] J. Rigelsford, "GSM Networks: Protocols, Terminology and Implementation," *Sens. Rev.*, 2003, doi: 10.1108/sr.2003.08723bae.001.
- [4] S. Redl, M. Weber, and W. H. Y. Are, *GSM and Personal*. 1998.
- [5] B. Schallock, C. Rybski, R. Jochem, and H. Kohl, "Learning Factory for Industry 4.0 to provide future skills beyond technical training," in *Procedia Manufacturing*, 2018, doi: 10.1016/j.promfg.2018.03.156.
- [6] G. Dinardo, L. Fabbiano, and G. Vacca, "A smart and intuitive machine condition monitoring in the Industry 4.0 scenario," *Meas. J. Int. Meas. Confed.*, 2018, doi: 10.1016/j.measurement.2018.05.041.
- [7] A. Pantelopoulos and N. G. Bourbakis, "A survey on wearable sensor-based systems for health monitoring and prognosis," *IEEE Transactions on Systems, Man and Cybernetics Part C: Applications and Reviews*. 2010, doi: 10.1109/TSMCC.2009.2032660.
- [8] Chaitali Bagwe, Vidya Ghadi, Vinayshri Naik, Neha Kunte, "IoT Based Gas Leakage Detecting System With Database Logging, Prediction and smart Alerting-Review", *IOSR Journal of Engineering (IOSRJEN)* ISSN (e):2250-3021, ISSN (p): 2278-8791 Volume 1 PP 25-28
- [9] Anandhakrishnan S, Deepesh Nair, Rakesh K, Sampath K, Gayathri S Nair, "IoT Based /smart Gas Monitoring System", *IOSR Journal of Electrical and Electronic Engineering (IOSR-JEEE)* eISSN: 2278-1676, P-ISSN: 2320-3331, PP 82-87
- [10] "IoT Gas Pipe Leakage Detector Insect Robot", <https://nevonprojects.com/iot-gas-pipeleakagedetector-insect-robot/>