

COPY RIGHT

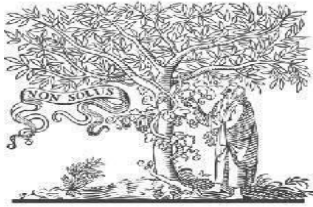

ELSEVIER
SSRN

2021IJIEMR. Personal use of this material is permitted. Permission from IJIEMR must be obtained for all other uses, in any current or future media, including reprinting/republishing this material for advertising or promotional purposes, creating new collective works, for resale or redistribution to servers or lists, or reuse of any copyrighted component of this work in other works. No Reprint should be done to this paper, all copy right is authenticated to Paper Authors

IJIEMR Transactions, online available on 20th Jan 2019.

Link : <https://ijiemr.org/downloads/Volume-08/Issue-01>

Title: **Multi Functional Monitoring System For Vehicles**

volume 08, Issue 01, Pages: 102-108

Paper Authors: **Vuduthala Srinivas¹, M.Kranthi Kumar²**



USE THIS BARCODE TO ACCESS YOUR ONLINE PAPER

Multi Functional Monitoring System For Vehicles

Vuduthala Srinivas¹, M.Kranthi Kumar²

Associate Professor¹, Assistant Professor²

Department of ECE
MREC

Abstract- Instead of having the single application in a system it is better to have multiple applications such that the user can run the vehicle safely and can avoid the accident. Here in this paper we are using a combination of different technologies such as GPS, GSM Technology. Now a days drunken drivers are increasing enormously. Due to this drunken driving, accidents are occurring at high rates. The main reason for driving drunk is that the police are not able to check each and every car. So we need an effective system which checks whether the driving person has drunken or not. Then it checks the seat belt is inserted properly or not. Vehicle will be automatically off when the system senses alcohol or seat belt is not properly inserted. Including with above applications, there is a CO sensor for monitoring the CO level which is emitted from the car and ultrasonic sensor for obstacle detection. The car is embedded with all the above technologies. If suddenly the vehicle met with an accident automatically the information will be transmitted to the nearest control room/medical rescue team by using an advanced GSM device which better suits for faster communication.

Index Terms- ARM, GPS, GSM, ALCOHOL SENSOR

I. INTRODUCTION

In this modern, fast moving and insecure world, it is become a basic necessity to be aware of one's safety. Maximum risks occur in situations when people travel in vehicles. Now a days road accident is a major problem all over the world. The recent report says that annual average of 700,000 road accidents, 10 percentages occur in India. The latest annual statistics revealed by the world health organization (who) in its first global status report on road safety, 80,000 people are killed on Indian roads due to speeding, drunken driving, less usage of helmets, seat belts and child restraints in vehicles. It states that the drunken driving is a major factor for the rising of death on roads.

The drunk driving fatalities in the year 2009, till the 27th November were 11,769. The numbers for 2007 and 2008 were 12,998 and 11,773 respectively. It shows that the problem of drunk driving is far from over. In the 2009 DUI national statistics released by the NHTSA (National Highway Traffic Safety Administration) 11,773 people died in alcohol-related crashes. Most of the accidents occur outside the cities are due to drunken driving and no testing methodology is adopted to avoid these fatalities in highways. Though having these system adopted to the vehicles if any accident occur that is in case of an emergency! Here's a system that functions as a drunken drive protection and accident alert system. It's the system such that ignition will be off when it detects alcohol and it gives the vehicle position whenever vehicle met with an accident in remote location. GPS module attached to the vehicle which needs to be tracked. The GPS module has the longitude latitude values and these parameters are sent to nearest traffic police /rescue team with GSM unit attached to vehicle.

Wearing the seat belt is an important issue, it is not possible to check each and every car whether the person has keep the seat belt are not. Seat belt can prevent many injuries in various types of accidents. It reduces the possibility of the occupant striking the interior of the vehicle position in relation to the airbag so that occupant can benefit from its deployment, if required.

So our proposed system needs to check the seat belt position. Being with these applications it needs to monitor the CO level and obstacle distance. Because now a days number of vehicles are increased heavily, so environment is polluted with carbon monoxide emitted from vehicles in cities.CO Exposures at 100 ppm or greater can be dangerous to human health.

When driver feel sleepiness or not concentrating on driving or the objects on road are invisible to driver in the nights or rainy days and when reversing the vehicle, it is important to detect the obstacle distance for avoiding the collision.

II. LITERATURE SURVEY

A. Microcontroller (MINI2440)

In this project, ARM-9 microcontroller acquires and Stores different parameter of vehicle. The main block of multi-functional monitoring system is ARM-9 micro controller which is heart of the system which provides monitoring and controlling actions. It senses signals from input blocks and processes output blocks. The software program is stored in ARM- 9 microcontroller on chip memory, according to which it provides the controlling actions. The on chip ADC converts these parameters into digital form and gives to the ARM-9 microcontroller. The LCD block is provided for visual display of the message. Also it continuously displays the measured parameters. The RTC provides real time clock depending on which the various events occur. Whenever accident takes place the accident interrupt block gives interrupt to the ARM-9 microcontroller. Through serial communication block the system is interfaced the PC. With this interfacing the stored data is transferred serially to PC, for the analysis purpose.

B. Alcohol Sensor

ARM microcontroller first reads the value of alcohol sensor if any alcohol is detected in the driver's cabin, the ignition is turned off. Generally there are so many methods to detect the alcohol. But we are using MQ-3 gas sensor (alcohol sensor) because of low cost and high performance. When it senses the alcohol its resistance value drops leads to voltage changes. Generally the illegal consumption of alcohol during driving is 0.08mg/L as per the government act. But for demonstration purpose, we programmed the threshold limit to low level.

In the implementation of our prototype system, the alcohol sensor (MQ3)is used. MQ-3 gas sensor has high sensitivity to Alcohol, and has good resistance to disturb of gasoline, smoke and vapor. The sensor could be used to detect alcohol with different concentration. It is with low cost and suitable for different application. Also it has Long life and low cost and simple drive circuit.



Fig.1: Alcohol sensors

C. Accident alert sensor

Here we are using SWITCHES/MEMS to detect accident. Micro-electro-mechanical systems (MEMS) technology has contributed to the improved performance, reliability and lower-cost -free and are durable for long periods; they sensors that support basic automobile functions within the automotive industry. They are deterioration have good dynamic characteristics, superior impact resistance, low power consumption, low cost, they are small in size, and easy for installation. When a vehicle meets with an

accident immediately Vibration sensor will detect the signal or if a car rolls over, and Micro electro mechanical system (MEMS) sensor will detects the signal and sends it to ARM controller. Microcontroller sends the alert message through the GSM MODEM including the location to police control room or a rescue team. So the police can immediately trace the location through the GPS MODEM, after receiving the information. Then after conforming the location necessary action will be taken. If the person meets with a small accident or if there is no

serious threat to anyone's life, then the alert message can be terminated by the driver by a switch provided in order to avoid wasting the valuable time of the medical rescue team.

D. GPS and GSM unit

The GPS unit sends the co-ordinates to the μc which stores these co-ordinates in its ram location. Also various other parameters are also stored in μc . Then after a specific time μc sends this data to the base unit (surveillance unit) with the help of on board GSM modem with help of AT commands. A GSM modem is a wireless modem that works with a GSM wireless network. A wireless modem behaves like a dial-up modem. The main difference between them is that a dial-up modem sends and receives data through a fixed telephone line while a wireless modem sends and receives data through radio waves.

E. SMS Sending Mode

In this mode the system sends either SMS or directly dials calls to prerecorded numbers. The main blocks of this mode are microcontroller, mode interfacing unit and accident interrupts.

F. Seat Belt Checking Device

In this project we are using infrared emitters and detectors as seat belt checking device. An IR transmitter is designed through an IR led with a series resistance. The IR receiver section contains a photodiode which receives the IR rays and on the basis of IR intensity provides variation in

voltage. The analog voltage obtained is in between its maximum and minimum operating range. This analog variation of voltage is fed to the microcontroller. Emitter in one knob and detector in another knob, when these two knobs are connected properly (i.e., detector detects the IR light) then only the vehicle will start otherwise it will not start.

G. Ultrasonic Sensor (Obstacle Detection)

To detect any obstacle, an ultrasonic sensor is used. If any obstacle is observed within the specified range, an audio indication is given by the buzzer and it will display the distance of near object (front and rare). Ultrasonic sensor works on the piezoelectric principle. Piezoelectric ultrasonic sensors use a piezoelectric material to generate the ultrasonic waves. An ultrasonic sensor transmits ultrasonic waves into the air and detects reflected waves from an object.

We are using a maximum detection distance of 150cm for obstacle detection (ultrasonic sensor). The distance of the object is measured and displayed on LCD. And we have to program the system such that it will give a buzzer sound whenever the distance measured is 10 or 20 cm (specific range).

H. CO sensor

Carbon monoxide (CO) is a colorless, tasteless, odorless gas that comes from the incomplete burning of fuel. A carbon monoxide detector or CO detector is a device that detects the presence of the carbon monoxide (co) gas in order to prevent carbon monoxide poisoning. CO detectors are designed to measure co levels over time and sound an alarm before dangerous levels of CO accumulates in an environment

III. IMPLEMENTATION

BLOCK DIAGRAM:

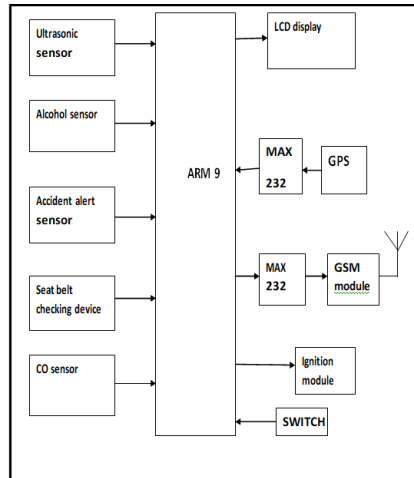

Fig.2: Block diagram

Software Algorithm

A. Algorithm of system work

- 1) Start
- 2) Check the seat belt and alcohol level
- 3) Send the collected information to the arm
- 4) Then ARM process the data
- 5) If seat belt is not inserted properly or alcohol level exceeds then ARM send command to relay to stop the ignition, otherwise not.
- 6) Check the co level and obstacle distance and send data to arm
- 7) Process the data in arm and displays their values. If the parameter exceeds the limit it will give a buzzer sound
- 8) If any accident occurred, process the data in arm then wait for 30 seconds.
- 9) If switch pressed, terminate the data otherwise send the information to control room /medical rescue team.
- 10) Exit

B. Flow of operation

In the implementation of our prototype system, we are using IR pair (i.e, IR transmitter and detector) for checking seat belt position. There are two knobs one is transmitter another one is detector, when these two knobs are connected properly then

SCREENSHOTS:

only ignition will be on otherwise it will be off. Then it goes for the alcohol detection.

We are using MQ3 alcohol sensor. MQ-3 gas sensor has high sensitivity to Alcohol, and has good resistance to disturb of gasoline, smoke and vapor. It is of low cost. The sensor will detect the alcohol presence, if the predefined limit exceeded, corresponding message will be shown on LCD with giving a buzzer sound. Then it goes for the next step.

The system will continuously monitor the CO level and obstacle distance, if the predefined limit exceeds, it will give a buzzer sound. It will display the distance of near object (front/rare). Then it go for accident detection.

For accident alert we are using MEMS (vibrating sensors) in our system. When vehicle met with an accident GPS unit will have longitude latitude values from the satellite and these are sent to microcontroller, then microcontroller will send to base station via GSM. The system will wait for some time (30 sec.) for the action of user. If user press the terminate switch then the system will terminate the information which is send to rescue team instead of wasting their valuable time in case of minor accidents. Otherwise it will send the information to rescue team.



Fig.3. Mini 2440

IV. RESULTS AND DISCUSSION

We continuously scan for various parameters of car, such as alcohol, seat belt position, accident alert sensors and ultrasonic, carbon monoxide sensors. The μ C stores all this data in the internal memory. If the driver is found to have alcohol in the breath, it warns and then turns the ignition off (if μ C is set with threshold values is set.) And hence possibility of an accident is avoided. Also we have designed an ultrasonic sensor, CO sensor which continuously monitors related parameters, if predefined limit exceeded, in that case a buzzer is operated.

Seatbelt checking device will continuously monitor the seat belt position. So it reduces the possibility of the occupant striking the interior of the vehicle. The accident location can be found easily. In this approach the accident is detected by micro- electro mechanical sensor and there is an alternative way provided to stop the whole process of messaging through a switch. Whereas the other approaches provide only one way of detecting the accident. Hence this paper has an edge over the other earlier approaches.

On the base side we receive the data such as the GPS coordinates on the online Google maps. The PC unit has the online VB software which graphically shows all the data to the analyst so that the location of accident can be found. Then necessary actions will be taken.

V. CONCLUSION

An effective solution is provided to develop the multi functional monitoring system which will monitor the various parameters related to vehicle such that the user can avoid the

accident and can run vehicle safely. And we can control environment pollution due to heavy emission of carbon monoxide. We think with some improvements the system can be used in real life.

REFERENCES

- [1] Road accidents in India [online] 2007 June 25. Available from:URL:<http://www.easydriveforum.com/f44-share-your-roadexperience/road-accidents-in-india-834.html>
- [2] Articles base directory [online] 2011 Feb. 16 Available from:URL:<http://www.dwworld.de/dw/article/0,,5519345,00.html>
- [3] Article from The Hindu [online] 2011 Feb. 10 Available from:URL:<http://www.hindu.com/2011/02/10/stories/2011021063740500.html>
- [4] Nissan to drink drive-proof its vehicles, September 2006, [http://www.nissanglobal.com/EN/NEWS/2007/_STORY/070723-01]
- [5] Raj Kamal, EBEDDED SYSTEMS, Architecture, Programming and Design, Second Edition, TATA McGraw-Hill Publishing Company Limited, 2008.
- [6] Shan Changing. The design of ultrasonic obstacle avoidance system based on S3C2410 [J]. Computer and digital engineering, 2009.2:55-57.
- [7] GSM User Manual, SIMCOM LTD, August 2006.
- [8] Arm User Manual, Phillips, August 2005.
- [9] MEMS User Manual, Free scale Semiconductors, 2009.
- [10] GPS Beginner's Guide, Garmin LTD, 2008